

lasting strength
with fibre-cement

nutec[®]
ROOFING AND CLADDING SOLUTIONS

Manufactured by
EVERITE
Established in 1941

FLAT SHEETS



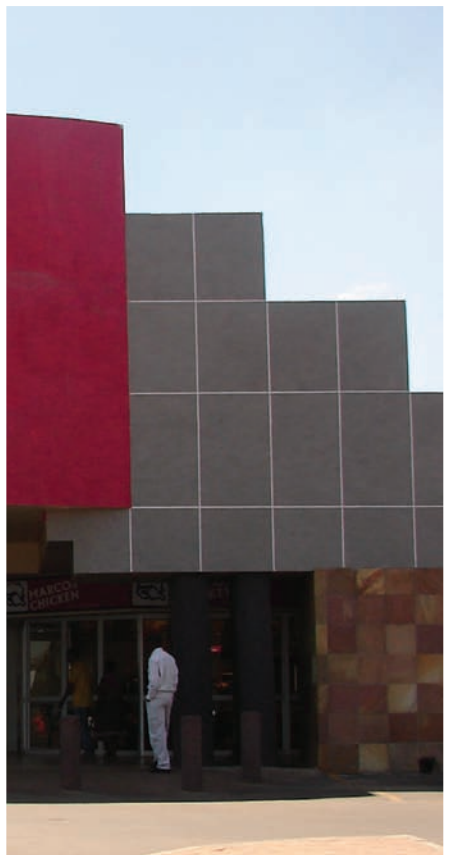

CONTENTS

About Everite and Nutec	2
Nutec Flat Sheets Features	4
Safety, Handling and Storage	5
General Design Criteria	6
Nutec Flat Sheet Product Range	8
Application Possibilities	9
General Installation Guidelines	10
Guidelines and Fixing Details	11
General information for Facades and Cladding	20
Facades and Cladding Fixing Accessories	21
Fixing Details for Facades and Cladding	22
Tongue and Groove Installation	32
Fire Resistance Systems	36
Acoustical and Thermal Values	40
Mechanical and Physical Properties	42
Everite National Offices and Contact Details	48

Catalogue Information

The information contained in this catalogue serves as a general guide only and should not be accepted as the standard for all construction. EVERITE can assist in designs of a special nature, however, architects, engineers and specifiers must finally approve the acceptability in terms of the design and construction criteria, as well as other implications.

About Everite and Nutec

■ Everite Building Products

Everite Building Products, wholly owned by JSE listed Group Five, has been associated with the South African building industry since 1941. Producing a wide range of materials that satisfy the needs of the commercial, industrial and residential market sectors, Everite is renowned for its comprehensive range of Nutec Roofing and Cladding Solutions and includes fibre-cement roofing, cladding, ceilings and building columns amongst others.

Nutec fibre-cement high performance properties and added benefits include: the use of safe renewable fibres; considerable tensile strength with enhanced dynamic load bearing properties; excellent thermal properties; water and wind resistance; hail resistance; fire resistance and resistance to fungus, rodents and acid.

A programme of quality assurance in accordance with the requirements of the International Standards Organisation (ISO 9001:2008) is entrenched in Everite's process and management systems. Quality of all products is continuously monitored as specified by the South African National Standards and recognised international bodies.

Everite's 54 hectare manufacturing facility near Johannesburg is well located and has immediate access to all major road and rail links to national destinations and major ports. The company has branches located at major centres throughout South Africa. Nutec products are distributed through leading stockists countrywide and an established export market further endorses the international acceptance of the Nutec Roofing and Cladding Solutions range of products.

■ Nutec

Nutec is the registered name for products manufactured without asbestos as a raw material. Nutec fibre cement products are manufactured using a mixture of cellulose fibre, cement, silica and water.

Through ongoing research and development, Everite Building Products are committed to provide product of world-class quality.

Accordingly, the Nutec product range is continuously reviewed not only in the interests of the end-user and superior product performance, but also with respect to its impact on the environment. Everite Building Products has over the years established a reputation for producing a variety of outstanding quality products which have been used in a wide range of external and internal applications.

Environmental benefits of Nutec Fibre Cement

- Environmental costs incurred by using fibre cement are measurably less than for other building materials. (Low embodied energy per m²).
- Requires less energy in assembly and construction than all other wall materials except timber.
- Low energy consumption in transportation and installation.
- Environmental costs relating to ozone layer depletion, carcinogenic substances and solid waste emissions are almost negligible.
- Low environmental impact in relation to ozone layer depletion, carcinogenic substances, and solid waste emissions.
- No pesticides are involved in the manufacture or use of fibre cement.

The benefits of Nutec Fibre Cement

- The use of safe fibres.
- Considerable tensile strength with enhanced dynamic load bearing properties.
- Cost competitive.
- Excellent thermal properties.
- Water tight and wind resistant.
- Hail resistant.
- Fire-resistant.
- Fungus and rodent resistant.
- Acid resistant.
- Complies with SABS ISO 9933.
- ISO 9001 : 2008 Quality Management System.

The environmental benefits in the manufacturing process of Nutec Fibre Cement

- Recycling the water used in production many times.
- Recycling solid wastes.
- Using sustainable raw materials in production.

Embodied Energy – Definition

Embodied energy is the energy consumed by all of the processes associated with the production of a building, from the mining and processing of natural resources to manufacturing, transport and product delivery. Embodied energy does not include the operation and disposal of the building material. This would be considered in a life cycle approach. Embodied energy is the 'upstream' or 'front-end' component of the lifecycle impact of a home. Fibre cement is one of the most energy efficient materials on the market and it has one of the lowest embodied energy contents per square metre of cover of any building product.

NUTEC FLAT SHEETS FEATURES

Nutec Flat Sheets

Nutec Flat Sheets are an economical, multi-purpose building board that can be used in diverse exterior and interior applications, ranging from cladding, eaves linings and fascias to ceilings, partitioning, panelling and suspended flooring.

Nutec High-Density and Medium Density flat sheets provide considerable scope for design flexibility and creative expression. Used as a flat vertical surface, Nutec Flat Sheets are produced in a smooth or textured finish. They are supplied in a neutral colour that can accept a wide variety of coatings and paints to suit the palette of any application.

The range includes Nutec Tongue & Groove that is available in a plain or realistic wood grain finish and is suitable for use in a variety of applications, both interior and exterior. Supplied in a natural colour and, as it is compatible with a variety of paints, the timber-like finish can be enhanced with wood stain varnishes or paint techniques.

■ Features

- An economical all-purpose building board which is unaffected by moisture and therefore ideal for internal and external use in almost any application.
- Relatively light in weight and can be supported on light gauge metal frames or light timber structures. These factors facilitate easy handling and erection and are major benefits on projects where low mass construction is an important factor.
- Non combustible and provide perfect protection against flying sparks.
- Resistant to corrosion and are unaffected by ultraviolet light.
- Designed to have good thermal properties when compared with other building materials. The thermal properties of Nutec Flat Sheets compare very well with other building materials available on the market.
For thermal conductivity values (K value), *refer to: Mechanical and Physical Properties.*
- Manufactured to the highest internal quality standards and compliance is ensured by strict quality assurance programmes in the production process as well as stringent testing in our laboratory. Nutec Flat Sheets are manufactured to the requirements of ISO 9001:2008.
- All Nutec Flat Sheets carry a SABS mark for compliance to the specification SANS 803.
- Nutec Flat Sheets are supplied in their natural colour, but are compatible with a large variety of in-situ applied coatings and paints. This will allow the designer an almost limitless combination of colours and textures for external and internal applications.

Safety, Handling and Storage Instructions

Safety

Safety rules as per current legislation and work practices as described in General Installation Guidelines must be observed when working with the product.

Nutec Flat Sheets as manufactured are made without asbestos fibres, it is nevertheless recommended that when working with the product, tools that create excessive dust should not be used. Ordinary carpenters' tools can be used effectively.

Handling

Nutec Flat Sheets are cement-based and may be damaged under excessively high shock loads. Reasonable care should therefore be taken to ensure that the products are not dropped or subjected to rough handling.

Storage

Nutec Flat Sheets should not be exposed to the elements and under cover storage is recommended. A smooth level under cover area should therefore be made available where they can be stacked safely. Nutec Flat Sheets should be stacked clear off the ground on suitable timber supports at maximum 400 mm centres and the edges and corners protected against possible damage.

Where under cover storage is not available, the stacked product should be covered to avoid it becoming soaked with water. Soaked boards will be difficult to handle and should be allowed to dry out before use.

GENERAL DESIGN CRITERIA

General Design Criteria

Recommended Uses

The recommended uses of Nutec Flat Sheets under normal conditions are tabulated for easy reference in [Table 2](#).

Mechanical and Physical Properties

Details on the mechanical and physical properties of Nutec Flat Sheets are scheduled at the end of this brochure.

Painting, Finishes and Coatings

The sheets are best painted with a pure acrylic PVA paint. Where it is intended to use oil or alkyd paints it is essential to prime the sheet with an alkali-resistant sealer. In this instance both faces of the product should be sealed.

Exposed and Windy Conditions

The information presented in this catalogue is a guide only for normal wind-loading conditions.

Please consult an Engineer or Architect for advice on specific fixing and framing recommendations for structures in normal-or high-wind areas.

Substructure Guidelines

The design of structural supports requires professional expertise and should be executed by structural engineers.

TABLE 1

Guideline - Supporting Structure for Nutec Flat Sheets		
	External and Internal Vertical Cladding	
Description and Thickness of Board	Maximum spans between vertical supports	Maximum spans between horizontal supports
Medium density 9 mm 12 mm	600 mm 800 mm	600 mm 900 mm
High density 10 mm 15 mm	600 mm 800 mm	800 mm 1 200 mm

- For specific fixing and framing recommendations where the sheets are to be used for applications such as floors, shelving and permanent shuttering, please consult an engineer or architect for details.
- If used for flooring, and covered with ceramic tiles or other inflexible material, expansion joints must be provided. Please refer to an engineer for details.

GENERAL DESIGN CRITERIA

Ventilation

When using Nutec Flat Sheets to form a double skin wall in a prefabricated steel or timber framed structure, the cavity (if not fully filled) between the two skins should be ventilated. In these structures, especially in humid conditions, foil is often installed as a moisture barrier and as an insulator. Ventilating the cavity will permit the evaporation of any condensation which may collect.

Site Service

Site service personnel are available on request to assist with recommended storage, handling and erection of the Company's products before and during installation.

NUTEC FLAT SHEETS PRODUCT RANGE

Product Range

■ Nutec Flat Sheets Product Range, Dimensions and Properties

Nutec Plain Medium Density (MD) Boards

Note: Chamfered boards available on request

Product No.	Nominal thickness mm	Size mm	Average Mass per unit (kg)
010-910	9 MD	2 400 x 1 200	38
010-911	9 MD	3 000 x 1 200	47
010-912	9 MD	3 600 x 1 200	52
011-210	12 MD	2 400 x 1 200	49
011-211	12 MD	3 000 x 1 200	61
011-212	12 MD	3 600 x 1 200	73

Nutec Plain High Density (HD) Boards

Note: Chamfered boards available on request

011-005	10 HD	3 000 x 1 200	61
011-006	10 HD	3 600 x 1 200	73
011-505	15 HD	3 000 x 1 200	87
011-506	15 HD	3 600 x 1 200	104

Nutec Textured Tongue & Groove Medium Density (MD) Boards

650-567	6 MD	1 200 x 2 400	24
650-568	6 MD	1 200 x 3 000	30
650-569	6 MD	1 200 x 3 600	37
060-643	9 MD	1 200 x 2 400	35
060-644	9 MD	1 200 x 3 000	44
060-645	9 MD	1 200 x 3 600	52

Nutec Plain Tongue & Groove Medium Density (MD) Boards

650-566	6 MD	1 200 x 3 000	30
---------	------	---------------	----

Nutec Floor Boards High Density (HD) Boards

011-504	15HD	1 800 x 1 200	52
---------	------	---------------	----



Nutec Textured Tongue and Groove



Nutec Plain Tongue and Groove

APPLICATION POSSIBILITIES

TABLE 2

Recommended Uses of Nutec Flat Sheets							
Product Description	Medium Density				High Density		
	9 mm Plain	12 mm Plain	6 mm Textured	9 mm Textured	10 mm Plain	15 mm Plain	
Internal panelling	•	•	•	•			
Gable cladding	•	•		•	•		
Prefabricated housing	•	•		•	•		
Steel & Timber frame houses & steel frame interior / exterior walls	•	•		•	•	•	
Partitioning	•			•	•		
Sandwich panels (Double skin light weight steel infill)	•						
Louvres		•			•	•	
Balustrading					•	•	
Steel beam and column lining (Aesthetic finish)	•	•			•	•	
Permanent shuttering						•	
Toilet and shower partitioning					•	•	
Floors						•	
External facades (stone chip finish)	•	•			•		
External facades (paint application)	•	•		•	•		
Suspended floors						•	

GENERAL INSTALLATION GUIDELINES

General Installation Guidelines

- To ensure a high standard of finish, it is essential that the supporting structure is accurately constructed. Warped, twisted or poor quality timber, or badly erected steelwork will reflect in the finished surface and can cause damage to the product.

The structure must be checked and adjusted as necessary to ensure that there is no bowing or distortion which could affect the true plane of the final application.

- For maximum spacings between supports for Nutec flat sheets, refer [Table 1](#) and [Fig. 9](#) for guidelines.

Sheets should not be fixed directly onto a masonry wall, but on timber or steel battens forming a framework to which the fascia boards or sheets can be fixed.

- Holes for fixing must be set out evenly and must be drilled and not punched.

An ordinary hand drill and steel drill bits specially sharpened to a 20° angle are recommended.

The drill bit must be 2 mm larger than the diameter of the fixing bolt or screw.

- When the sheets are fixed into a framed structure allowance must be made for thermal movements in the sheet and the supporting structure.

The allowance for movement will depend on the size of the sheet, but an average can be accepted as ± 2 mm per metre in both directions. For facade jointing, use recommended jointing details.

Installation Guidelines and Fixing Details

■ Special Fascia Boards

Fig 1 : Using Nutec Flat Sheets as a Special Fascia

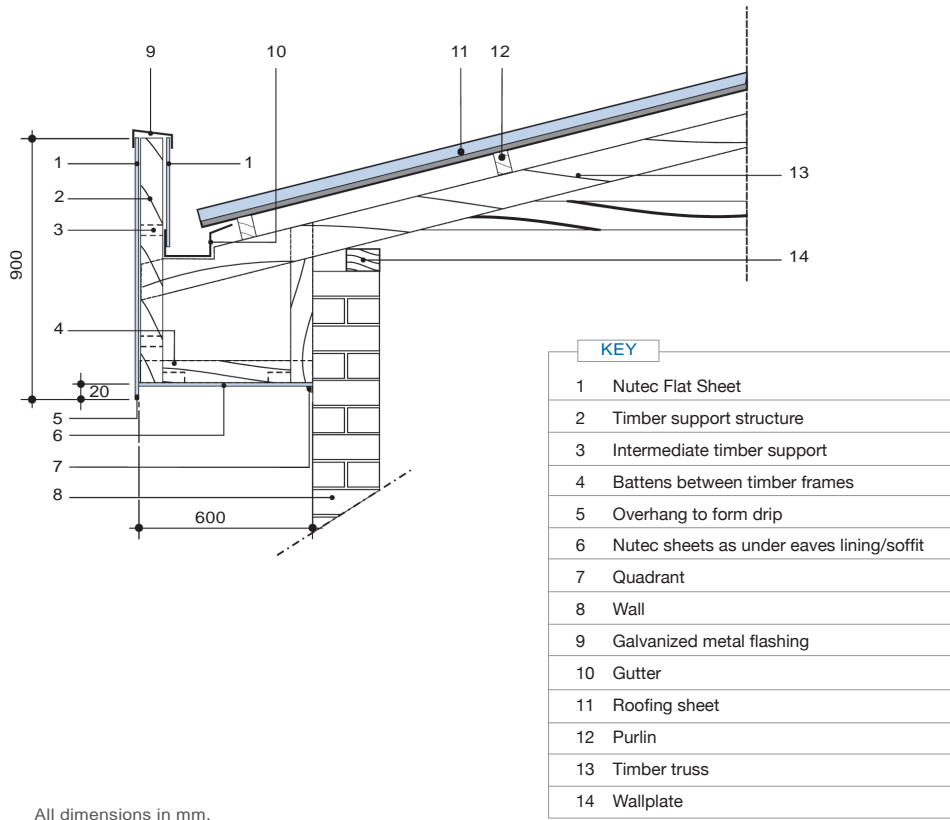

NB:

- In the above application 9 mm medium density sheets are used. In instances where ceramic tiles are fixed to a fascia, minimum thickness of sheets should be 10 mm high density or 12 mm medium density sheets.
- The flashing should be sloped away from the face of the fascia to avoid discolouration due to dust being washed down by rain over the finished surface.
- Guideline for spanning capabilities of NUTEC FLAT SHEETS, [Refer Table 1.](#)
- Fascias should not be fixed directly to a wall, use timber battens to provide a framework for the fascia.

INSTALLATION GUIDELINES AND FIXING DETAILS

■ Typical Layout of Nutec Flat Sheet on Timber and Steel Framework

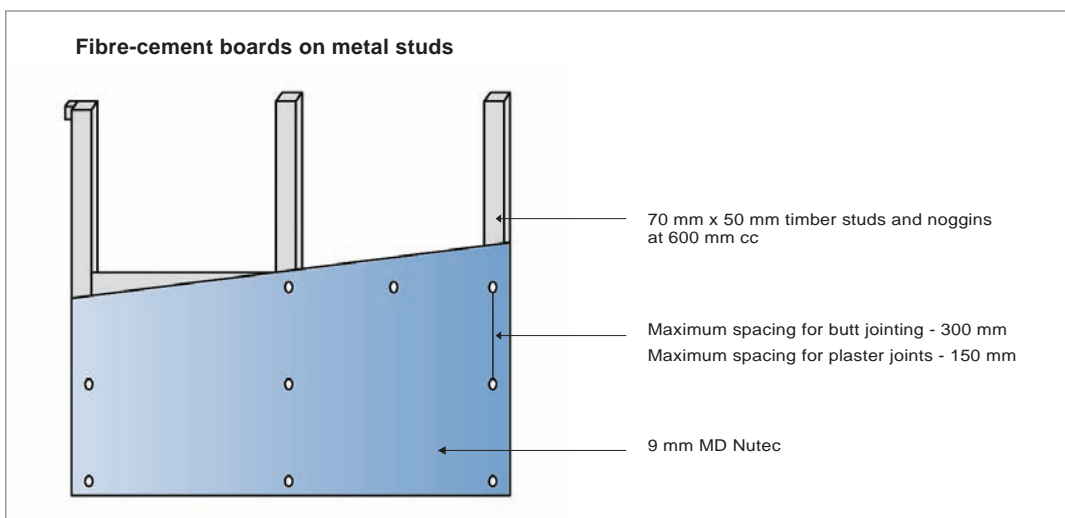
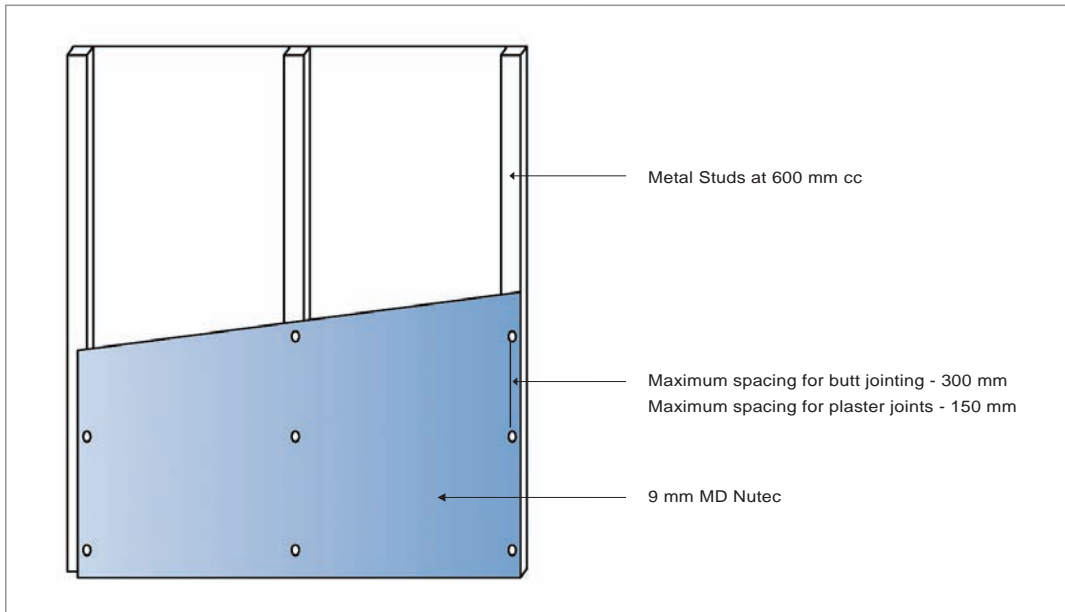

NB:

- Timber or steel framing may be used and should be constructed in accordance with local building regulations and acceptable building practice.
- Timber should be selected structural grade timber.
- Timber supports must be firmly secured to top and bottom plates and frames must not rely on the Nutec Flat Sheets for stability.
- Support spacings for external or internal walls should not exceed 600 mm centres.
- Framing members, should be arranged to support all sheet edges.
- Where the support faces behind sheet joints are less than 38 mm wide, pack out to provide additional landing for sheet fixing. [Refer Fig. 4.](#)
- For further information on timber framed structures, refer to SANS 10082.

INSTALLATION GUIDELINES AND FIXING DETAILS

Fixing of Nutec Flat Sheets to Support

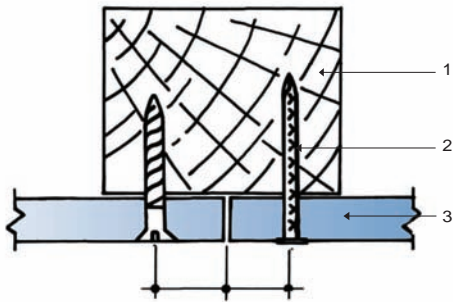

KEY

- | | |
|---|-------------------------------|
| 1 | Timber stud |
| 2 | Galvanised nail or wood screw |
| 3 | Nutec Flat Sheet |

Fixing of Nutec Flat Sheet to Narrow Support

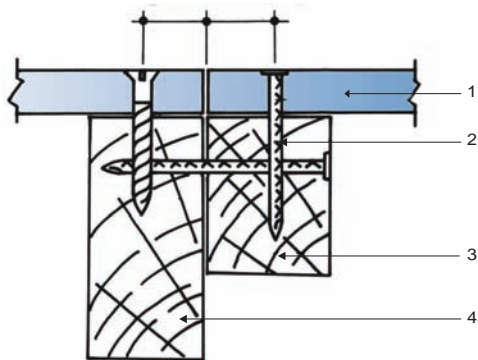

KEY

- | | |
|---|-------------------------------------|
| 1 | Nutec Flat Sheet |
| 2 | Galvanised nail or wood screw |
| 3 | Packing as required for narrow stud |
| 4 | Narrow stud |

■ Jointing

There are various methods that can be used for jointing.

Showing the Use of an H-profile Strip

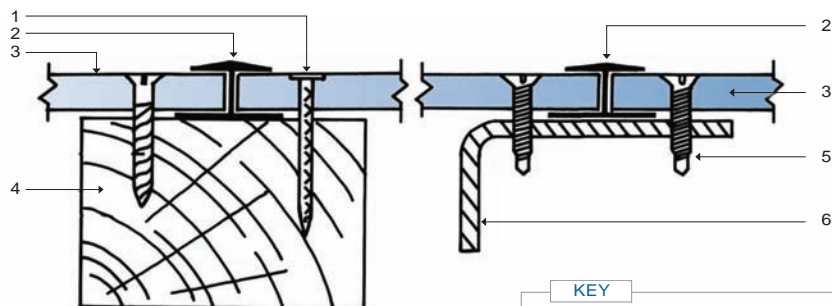

KEY

- | | |
|---|-------------------------------|
| 1 | Galvanised nail or wood screw |
| 2 | H profile jointing strip |
| 3 | Nutec Flat Sheet |
| 4 | Timber stud |
| 5 | Fixing screw |
| 6 | Metal frame |

INSTALLATION GUIDELINES AND FIXING DETAILS

Showing Mouldings Used as Cover Strips

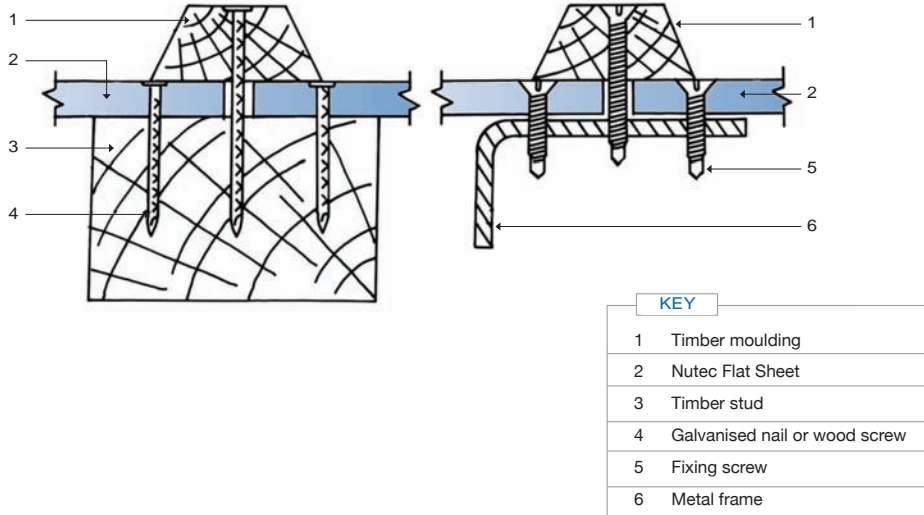

Illustrating the Use of Epoxy Fillers for Jointing

Jointing on a straight wall

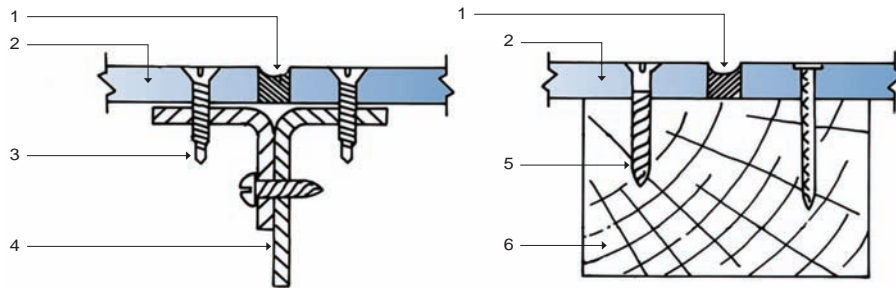

External corner joint

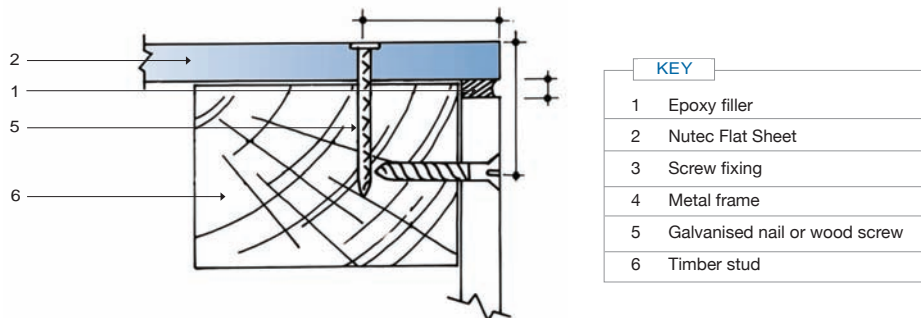

INSTALLATION GUIDELINES AND FIXING DETAILS

Illustrating the Use of Epoxy Fillers for Jointing (*cont.*)

Internal corner joint

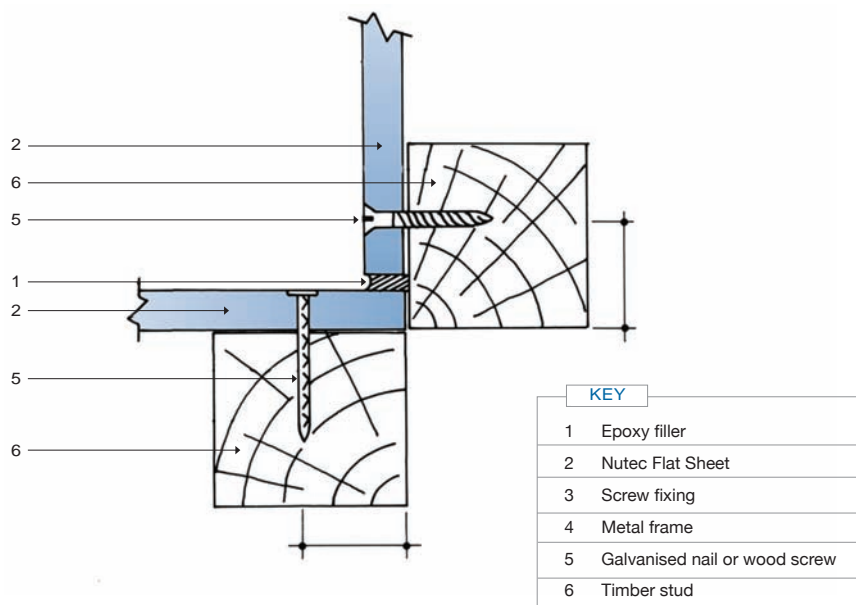

■ Typical Flush Jointing Application

Everite should be consulted for advice on specific application and recommended compounds to be used. For flush jointing of Nutec Flat Sheets, whether erected on steel studs or timber studs, the procedure is as follows:

- Prepare jointing compound as per manufacturer's instructions.
- A suitable plaster is recommended.
- Apply the mixture firmly into the joints between the edges of the board.
- To avoid premature drying out of the mixture do not fill joints longer than 5m at a time.
- Embed 'fibre tape' into the mixture using a spatula or plastering trowel and allow to dry thoroughly. *Refer Fig. 2.*
- Apply a coat of the mixture to nail or screw heads and allow to dry.
- After the base coat has thoroughly dried out apply further coats, allowing each coat to dry before the next coat is applied.
- Care should be taken to feather out each application so that a smooth joint results. The final coat is finished off by using a fine grit sand paper.
- For internal corners use 'fiber tape' and for external corners use a metal 'Corner Bead'. *Refer Fig. 2* and apply jointing compound as described above.

Fig 2 : Flush Jointing Application

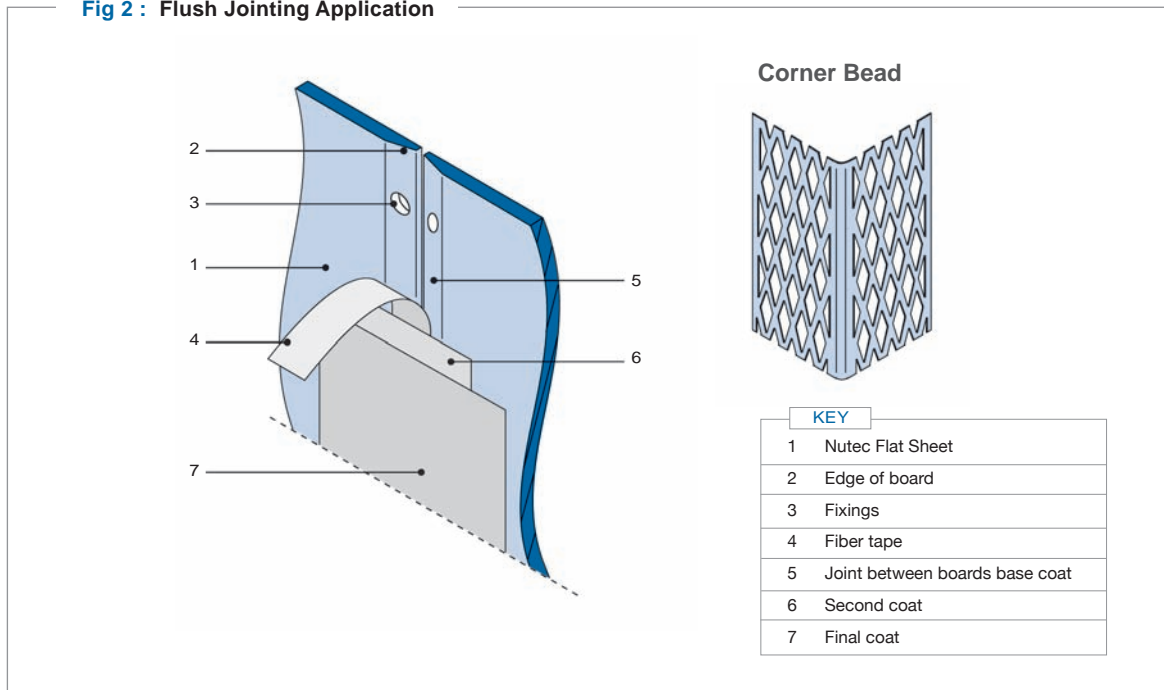

■ **Wall Tiling**

Where a partition wall is finished with ceramic wall tiles, the following procedures should be followed:

- **Reduce the stud spacing to a maximum of 400 mm.**
- Provide horizontal noggings between studs at 900 mm centres.
- External and internal corner studs must be joined together using a corner bead.
- Sealed both sides of the Nutec sheet with a concrete sealer.
- Before fixing tiles ensure that the boards are completely free of dust or grease.
- Using a notched trowel apply suitable tile adhesive to the partition board covering an area of 1m² at a time.
- Press tile firmly into the adhesive to ensure that no voids occur under the tiles.
- Allow a minimum gap of 2 mm between tiles for grouting.
- Directions for mixing of adhesive and grout should be obtained from the manufacturers.
- For bath, shower/wall junction detail refer to *Figs. 3, 4 and 5*.

Fig 3 : Bath/Wall Junction Detail Using Steel Frame

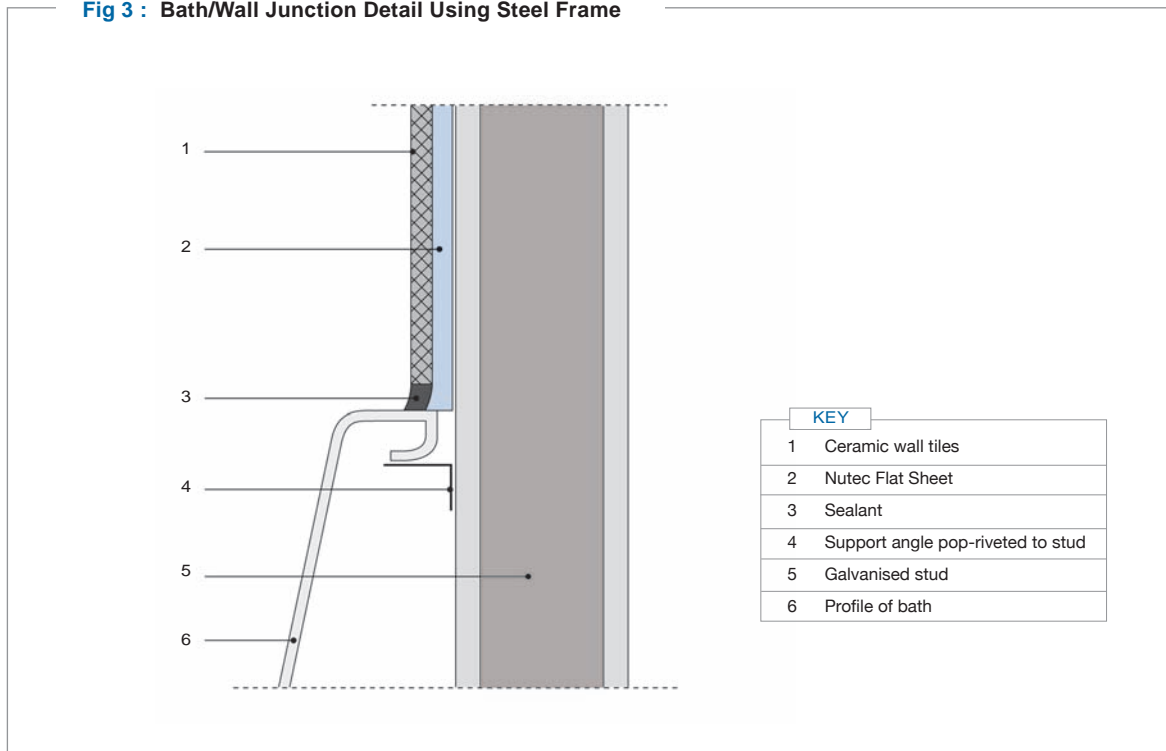

INSTALLATION GUIDELINES AND FIXING DETAILS

Fig 4 : Shower Base/Wall Junction Detail Showing Steel Frame

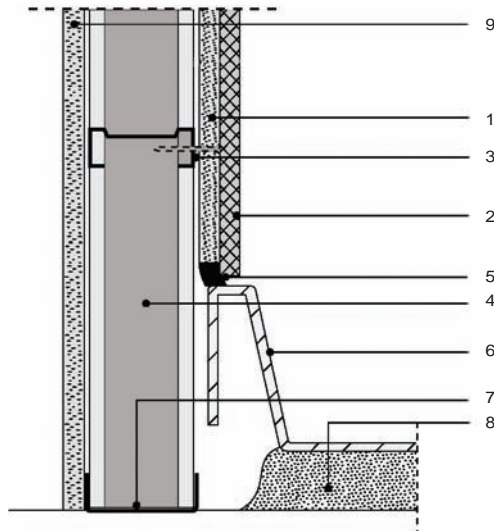

KEY

1	Nutec Flat Sheet
2	Ceramic tiles
3	Steel nogging
4	Galvanised stud
5	Sealant
6	Profile of shower base
7	Track
8	Screen bedding
9	Nutec sheet

Fig 5 : Base/Wall Junction detail using timber framing

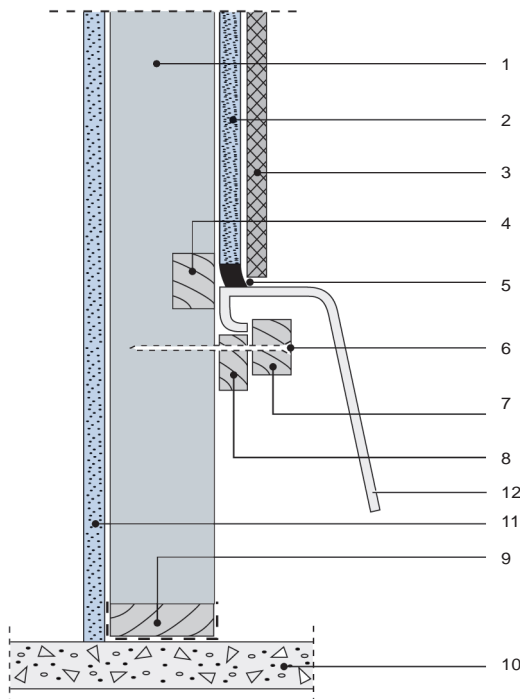

KEY

1	Timber stud
2	Nutec Flat Sheet
3	Ceramic tiles
4	Backing nogging
5	Sealant
6	Fixing point
7	Timber rail to secure rim of bath
8	Timber spacer
9	Base plate
10	Concrete floor slab
11	Nutec sheet
12	Bath

■ Nutec Flat Sheets in Shuttering Applications

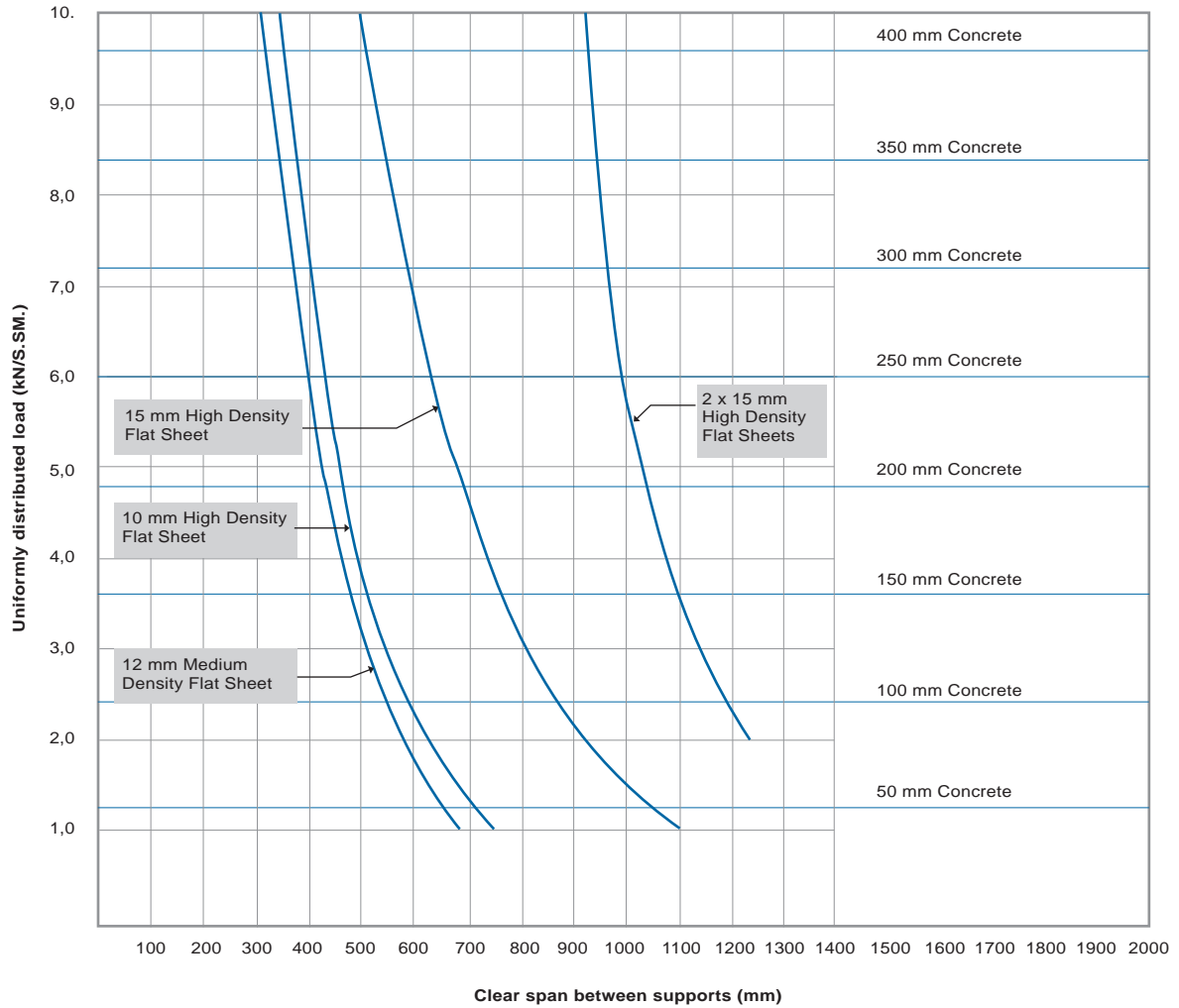

1. In 1 200 mm widths
2. Shuttering to have 25 mm minimum bearing at each end
3. Concrete must be spread evenly to avoid excessive heaping

Facades and Cladding

■ Application

Nutec Flat Sheets are particularly suitable where a light weight and durable cladding is required. They protect the structure, yet provide access to the many services which are required in modern buildings. An existing building can be given an entirely new facade without major alteration to its structural framework.

The availability of in situ coated surfaces presents the designer with an almost limitless combination of colour and texture.

Typical External Facade Fixing Accessories

*All products not supplied by EVERITE

Fixings	Facade				Moulded Panels	
	Steel Structure		Timber Structure			
Fastener	Flat Sheet Exposed Fixing	Flat Sheet Concealed Fixing	Flat Sheet Exposed Fixing	Flat Sheet Concealed Fixing	Fixed to Steel	Fixed to Timber
* Countersunk Head Brass Wood Screw 40 mm x 12 mm				●		●
* Self Tapping Screw Countersunk Head 35 mm x 5,5 mm		●			●	
* Drill Screw Countersunk Head 30 mm x 5,5 mm		●			●	
* Spade Point Screw Hexagon Washer Head 50 mm x 5,5 mm Steel Stainless Steel			● ●			● ●
* Drill Screw Hexagon Washer Head 50 mm x 5,5 mm Steel Self Tapping Stainless Steel	● ●				● ●	

EPDM Sealing Gaskets - for use with Nutec Flat Sheets having open joints

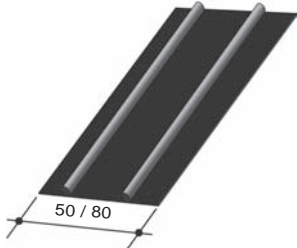
Sketch	Product No	Description	Size
 <p>All dimensions in mm.</p>	602-001	EPDM sealing gasket	50 m lengths x 50 mm wide
	602-002	EPDM sealing gasket	50 m lengths x 80mm wide

Epoxy Jointing Compound

Product No	Description	Size
630-100	Elibond FR964 (with UV stabiliser)	400 g
630-110	Epoxy Kit	1 kg

Other Items

- Silicone Sealer
- Galvanised Hoop Iron 50 mm x 0,5 mm
- Foam Backing Strip
- Fixings

Setting Out and Fixing Procedures for Nutec Flat Sheet Facade

For vertical runners or counter battens, cold rolled steel sections could also be used instead of timber as illustrated in [Fig. 7](#).

- Girts should be provided with elongated holes for fixing to supporting cleats - *refer to Fig. 7*.
This provides for adjustment of the girts to obtain a true fixing line for the panels.
- A basic framing layout is shown in [Fig. 8](#) and [Fig. 9](#) for flat sheets.

Fig 7

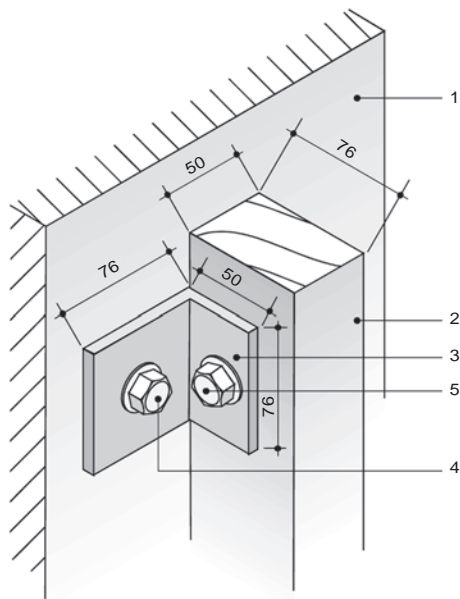

KEY

1	Main structure
2	Timber runner at 600 mm centres
3	Angle secured with rawl bolt
4	Rawl bolt
5	Bolt fixing to timber

- Holes can be elongated to allow for adjustment
- **Dimension of supporting structure to be confirmed by engineer**

All dimensions in mm.

Fig 8

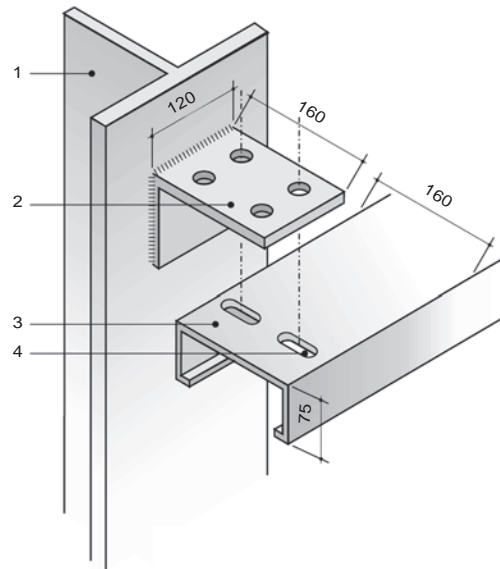

KEY

1	Structural member
2	Cleat welded to structural member
3	Cold formed steel girt
4	Elongated holes to allow for adjustment

- **Dimension of supporting structure to be confirmed by engineer**

All dimensions in mm.

FIXING DETAILS FOR FACADES AND CLADDING

- It is recommended that joints in each line of girts occur at the same column or supporting member.
- A minimum of 75 mm wide bearing surface required behind a horizontal joint to provide sufficient landing for screws to be placed at least 20 mm from the edge of the panels, [Fig. 8](#) and [Fig. 9](#), for flat sheets.

Fig 8 : Horizontal Girts (See Fig. 9 for Vertical Runners)

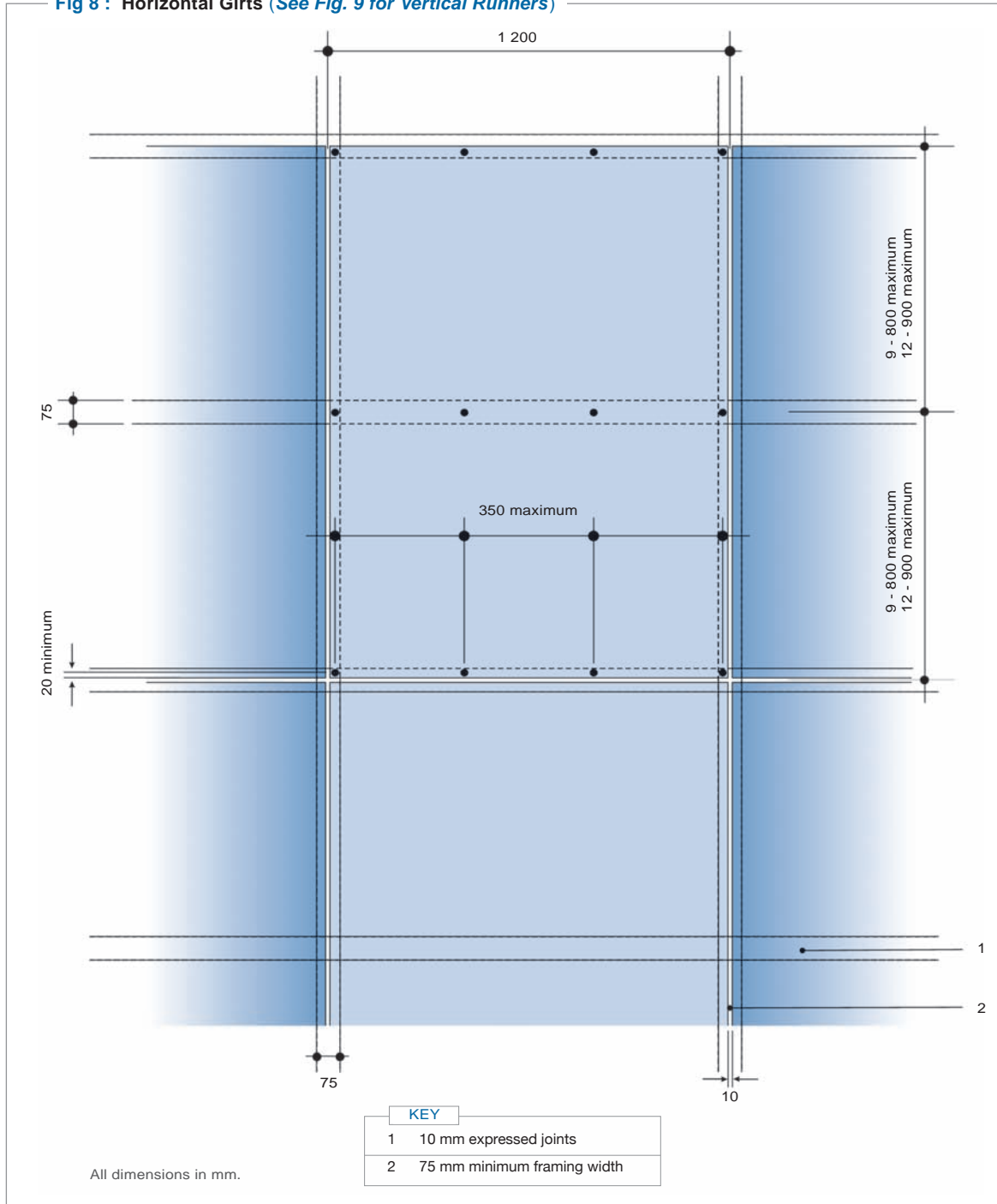

FIXING DETAILS FOR FACADES AND CLADDING

- The runners supporting the facades should not exceed 600 mm centres vertically and 800 mm centres horizontally. Framing members should be arranged to support all panel edges, *Refer Fig. 8 and Fig. 9.*

Fig 9 : Vertical Runners

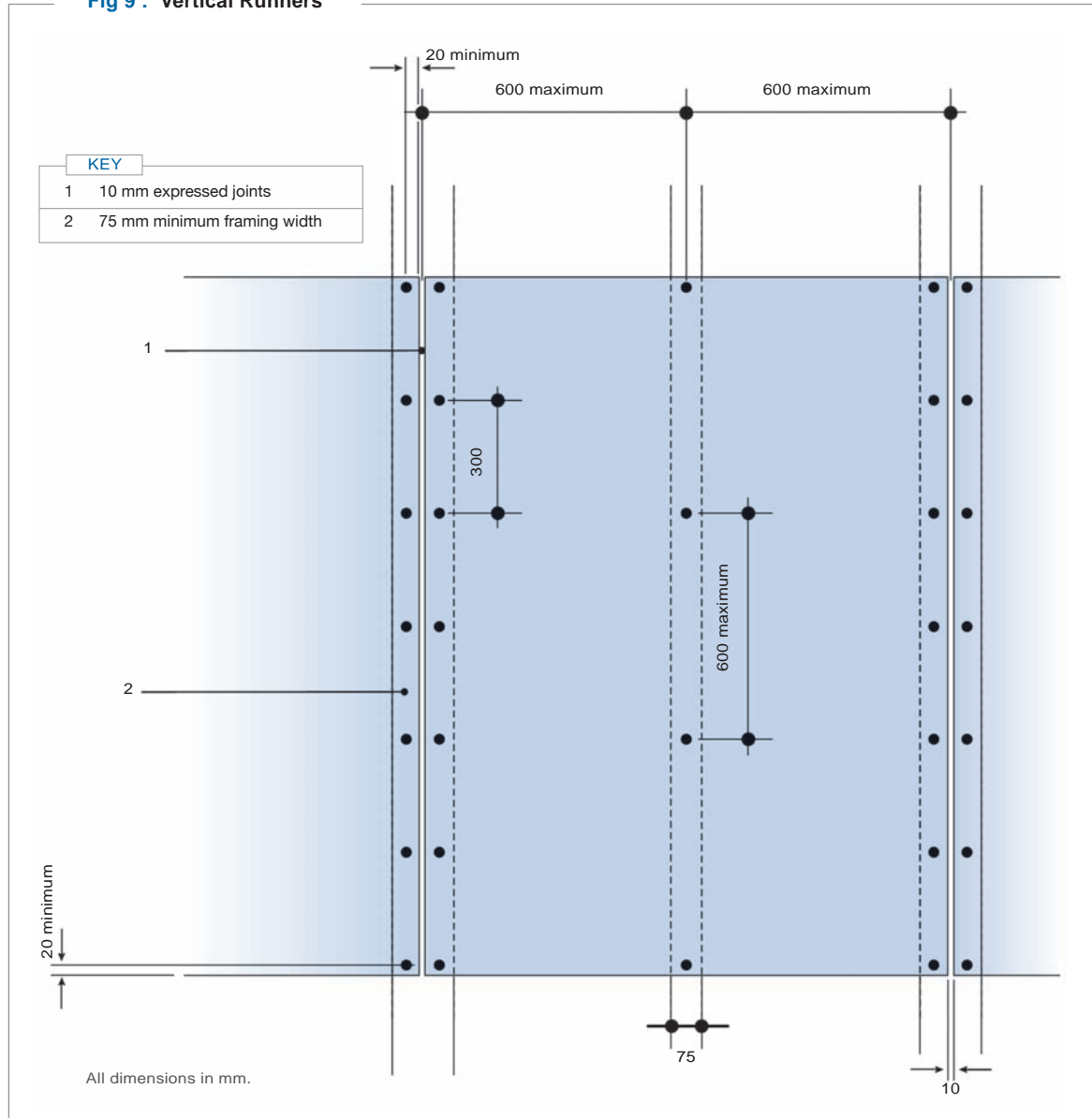

NB:

- For further design information or copy of the report on wind resistance tests performed by the CSIR, contact EVERITE Sales Office.
- The above is a guideline for wind loading conditions for structures not higher than 15 m.
- Please consult an engineer or architect for specifications to suit.

FIXING DETAILS FOR FACADES AND CLADDING

Fig 10 : Framing Behind Horizontal Joints / Vertical Joints

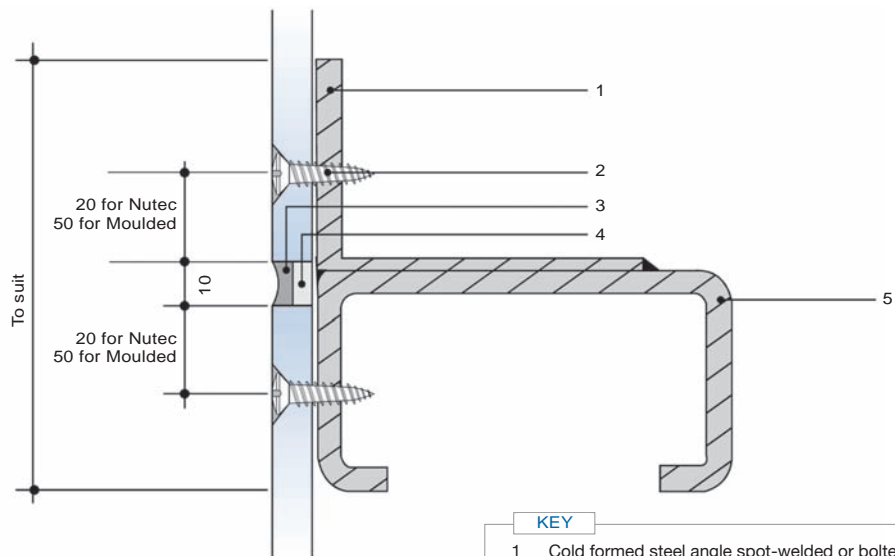

All dimensions in mm.

KEY

- | | |
|---|---|
| 1 | Cold formed steel angle spot-welded or bolted to girt |
| 2 | Fixing point |
| 3 | 10 mm open joint with silicone seal |
| 4 | Foam backing strip |
| 5 | Cold form steel girt |

Fig 11 : Counter Screw Detail

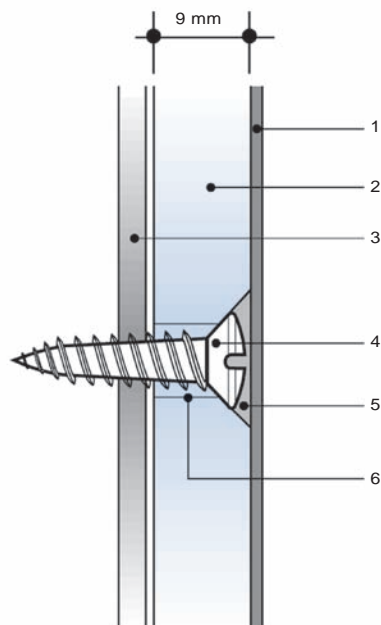

KEY

- | | |
|---|--------------------------------------|
| 1 | In situ coating as required |
| 2 | Moulded panel |
| 3 | Steel support rail |
| 4 | Countersunk self tapping screw |
| 5 | Epoxy filler sanded flush with panel |
| 6 | 2 mm oversize hole |

■ Nutec Flat Sheet Facade - Open Joints

For open vertical, horizontal and corner joints, EPDM gaskets are recommended. As an extra precaution against water penetration, silicone is used in conjunction with the EPDM gasket - [Fig. 12\(A\)](#) and [Fig. 12\(B\)](#), [Fig. 13\(A\)](#) and [Fig. 13\(B\)](#), [Fig. 14\(A\)](#) and [Fig. 14\(B\)](#).

For alternative horizontal joints, silicone is used. [Fig. 10](#) and alternative [Fig. 15](#).

Fig 12 (A) : Perspective of an Open Vertical Joint

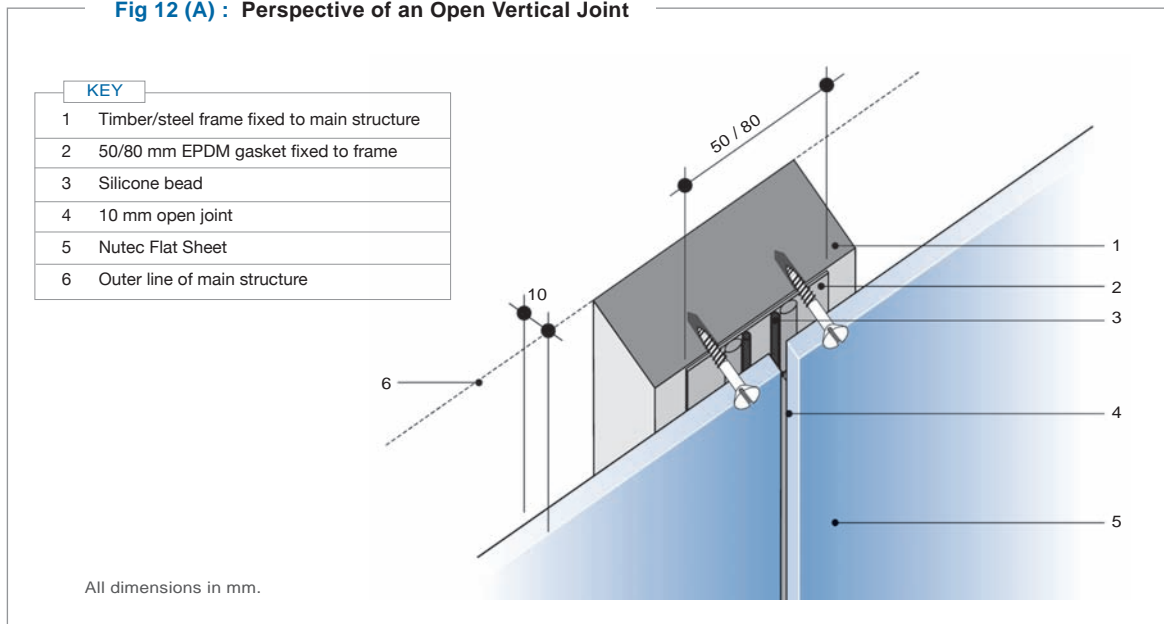
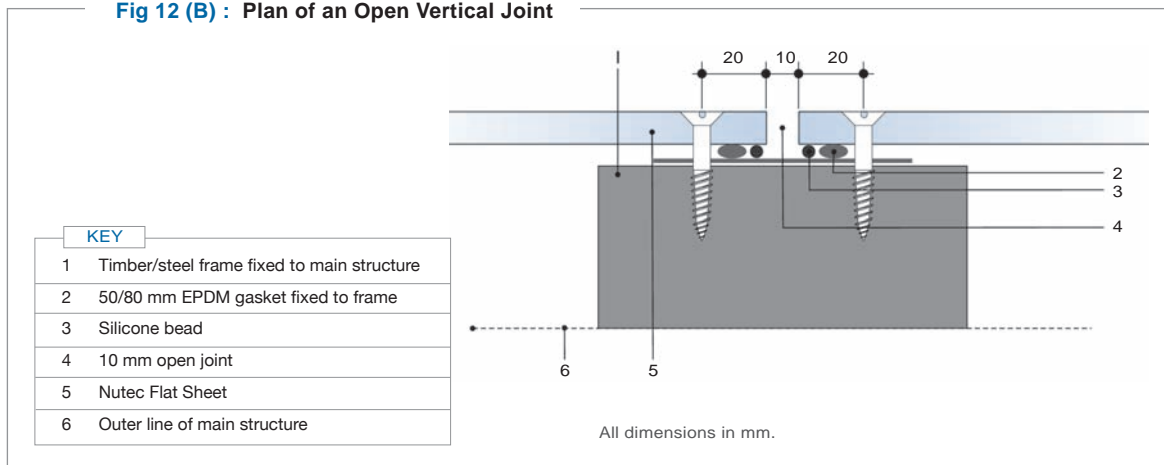

Fig 12 (B) : Plan of an Open Vertical Joint



■ Nutec Flat Sheet Facade - External Open Corner Joints

Fig 13 (A) : Perspective of an External Open Corner Joint

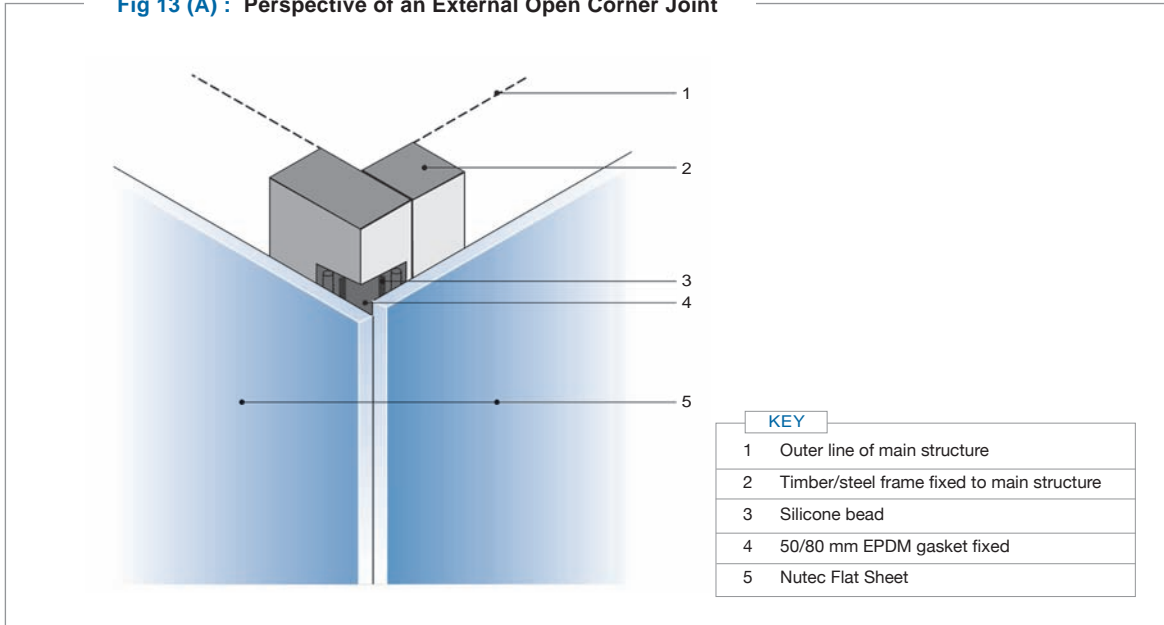
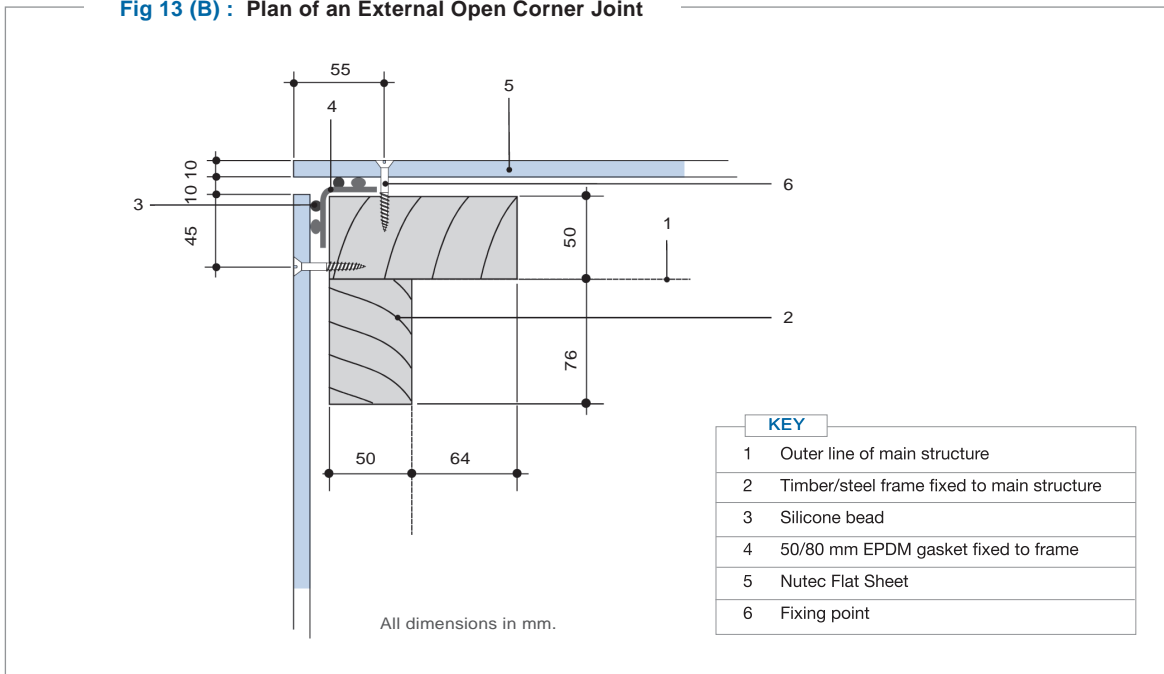
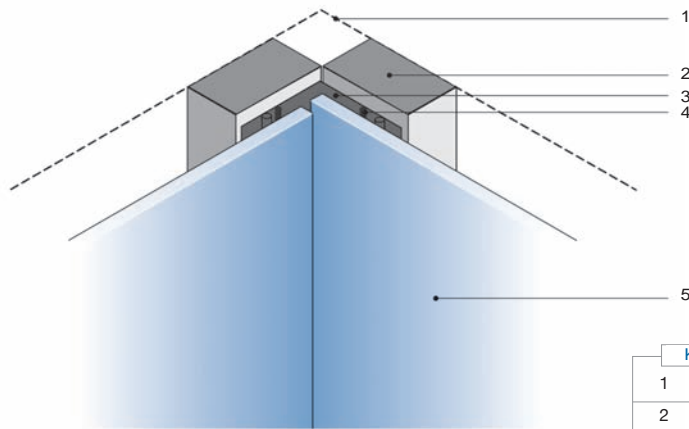

Fig 13 (B) : Plan of an External Open Corner Joint



■ Nutec Flat Sheet Facade - Internal Open Corner Joints

Fig 14 (A) : Perspective of an Internal Open Corner Joint



KEY	
1	Outer line of main structure
2	Timber/steel frame fixed to main structure
3	50/80 mm EPDM gasket fixed to frame
4	Silicone bead
5	Nutec Flat Sheet

Fig 14 (B) : Plan of an Internal Open Corner Joint

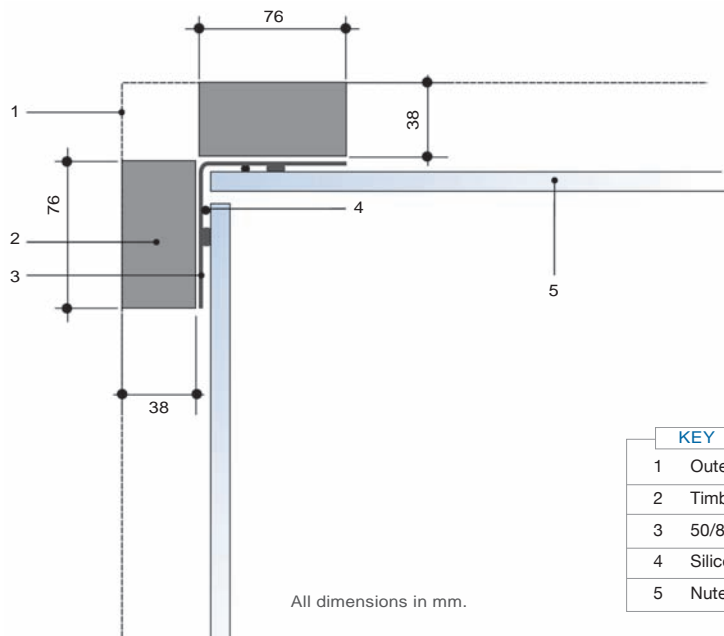

All dimensions in mm.

KEY	
1	Outer line of main structure
2	Timber/steel frame fixed to main structure
3	50/80 mm EPDM gasket fixed to frame
4	Silicone bead
5	Nutec Flat Sheet

■ **Nutec Flat Sheet Facade - Sealed Joints**

- For sealed joints, only silicones which are compatible with cement should be used.
- **Painting over sealants is not recommended.**
- The minimum joint opening should not be less than 6 mm and not more than 10 mm.
- The depth of the sealant should be half the sheet thickness.
- The edges of the material next to the joint should be parallel and relatively smooth.

Fig 15 : Sealed Joint Detail

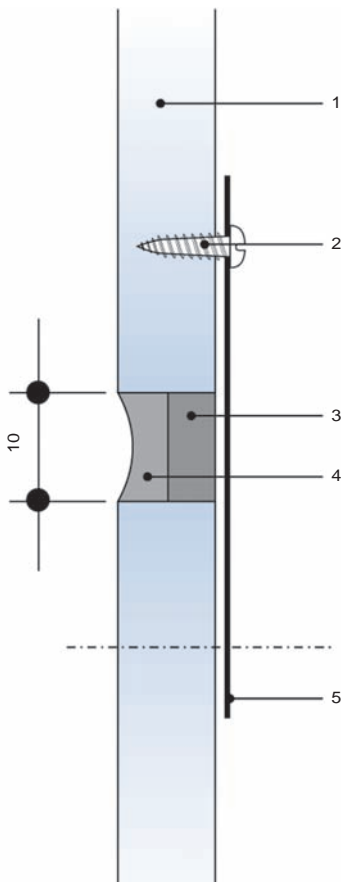

KEY

1	Nutec Flat Sheet
2	Self tapping or rivet (optional)
3	Foam backing strip
4	Silicone sealant
5	50 mm Galvanised hoop iron

All dimensions in mm.

Fig 16 : Plan of Window Detail showing Closed joint at Window Reveal

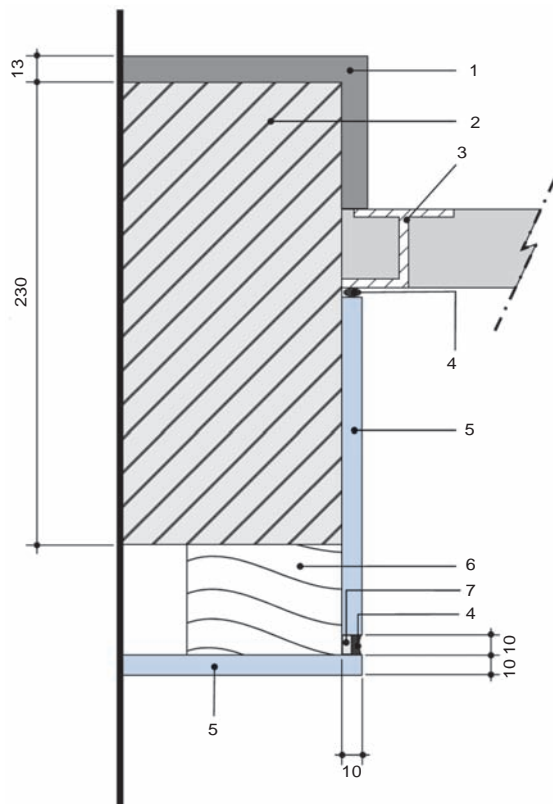

KEY

1	Plaster
2	Main structure
3	Steel window
4	Silicone sealant
5	Nutec Flat Sheet
6	Timber/steel frame
7	Foam backing strip

All dimensions in mm.

■ **Nutec Flat Sheet Facade - Metal Flashing Corner Details**

- Metal products not supplied by EVERITE.
- External and internal finishings are optional.

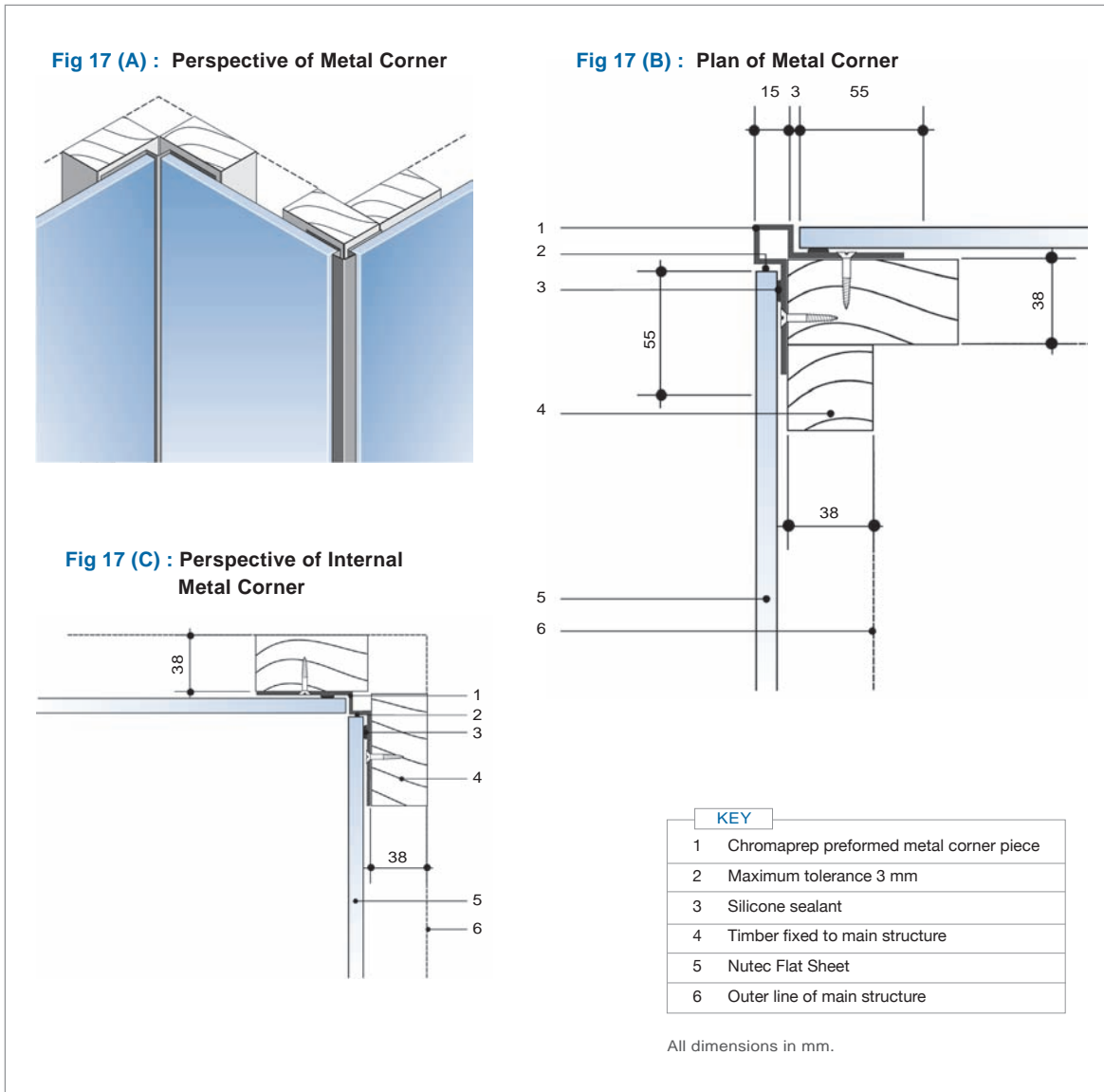

■ **Nutec Flat Sheet Facade General Details**

Where flashing is to be used on a parapet wall, it should wherever possible be sloped away from the face of the Nutec sheet in order to avoid any discolouration of the finished surface due to rain washing down dust onto the face of the sheet.

Fig 18 : Typical Section Through Window and Parapet Wall

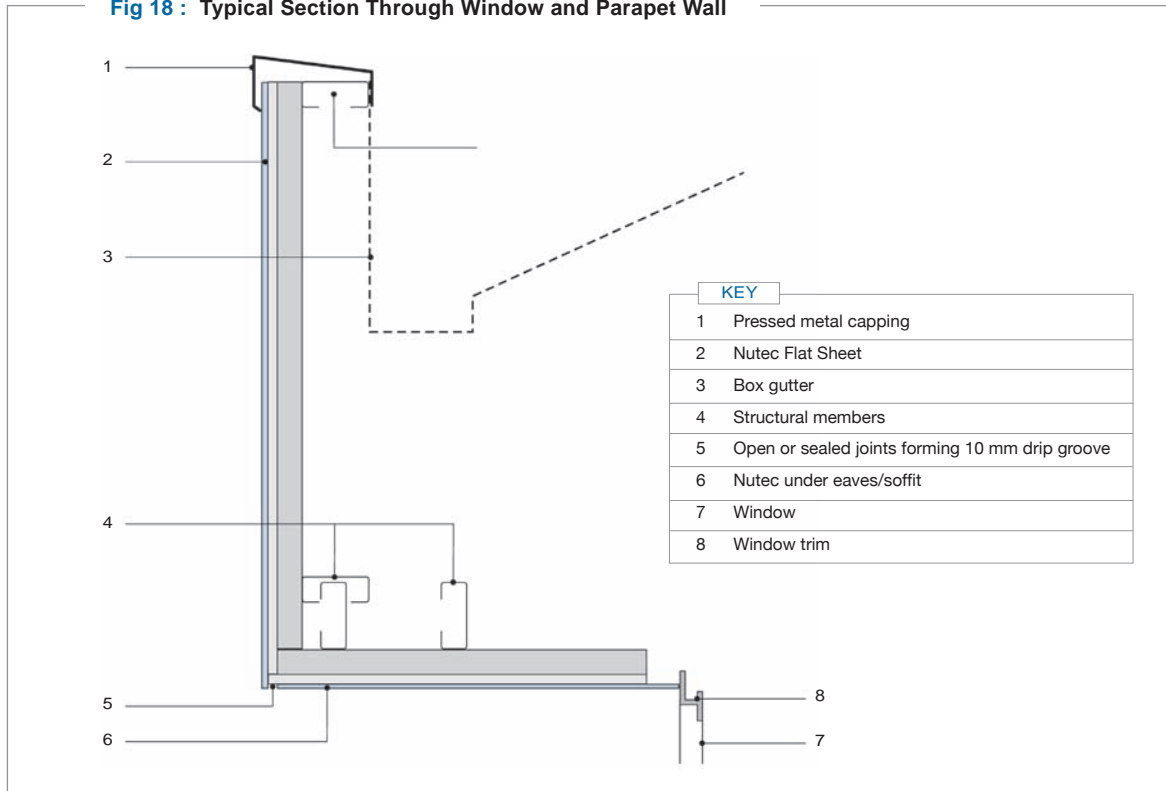
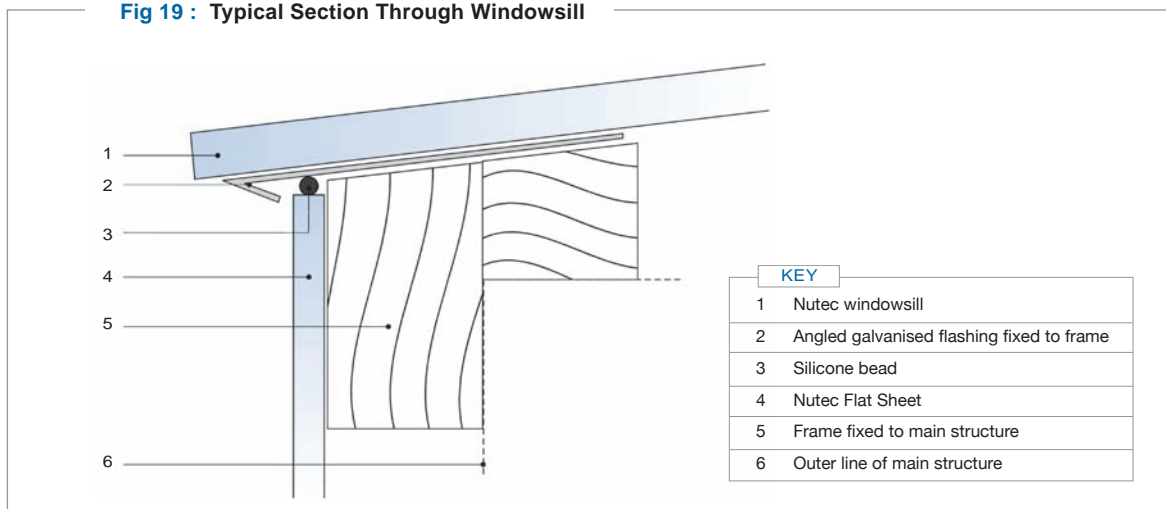

Fig 19 : Typical Section Through Windowsill



TONGUE AND GROOVE INSTALLATION

Nutec Tongue and Groove Boards

Nutec Tongue and Groove Textured and Plain boards are medium density. These sheets are supplied in the natural grey and can be varnished with wood stain to simulate timber. Textured sheets can also be painted in various techniques to achieve a pleasant aesthetic finish. These boards are ideal for ceilings, internal and external wall panelling, door panelling and garden sheds.

Tongue and Groove Plain boards provide a classic smooth Tongue and Groove finish.

■ Fixing and Installation Details

Guideline - Supporting Structure for Nutec Tongue and Groove Boards (Interior Application)		
Maximim Span Between		
Description and Thickness of Board	Vertical supports	Horizontal supports
6 mm	570 mm	500 mm
9 mm	570 mm	800 mm

1. Cut the board to the correct size using a masonry cutting disk and place onto the wall in the desired position.
2. Drill 5 mm holes through the board at the fixing points and fasten the board to the wall using a 5 x 30 mm (minimum size) nail in screws with wall plugs. Cut nails can be used on plastered brick walls.
3. Make sure the screws are countersunk into the board when fastened.
4. Adjoining boards are butt joined together to simulate an extra 'groove' (5 mm apart).
5. Use crack filler to cover the screw heads and fill the butt joint leaving a smooth finish, (eg. Painter's mate).

Fig 20 : Flush, internal and external joints for Nutec Tongue and Groove Boards.

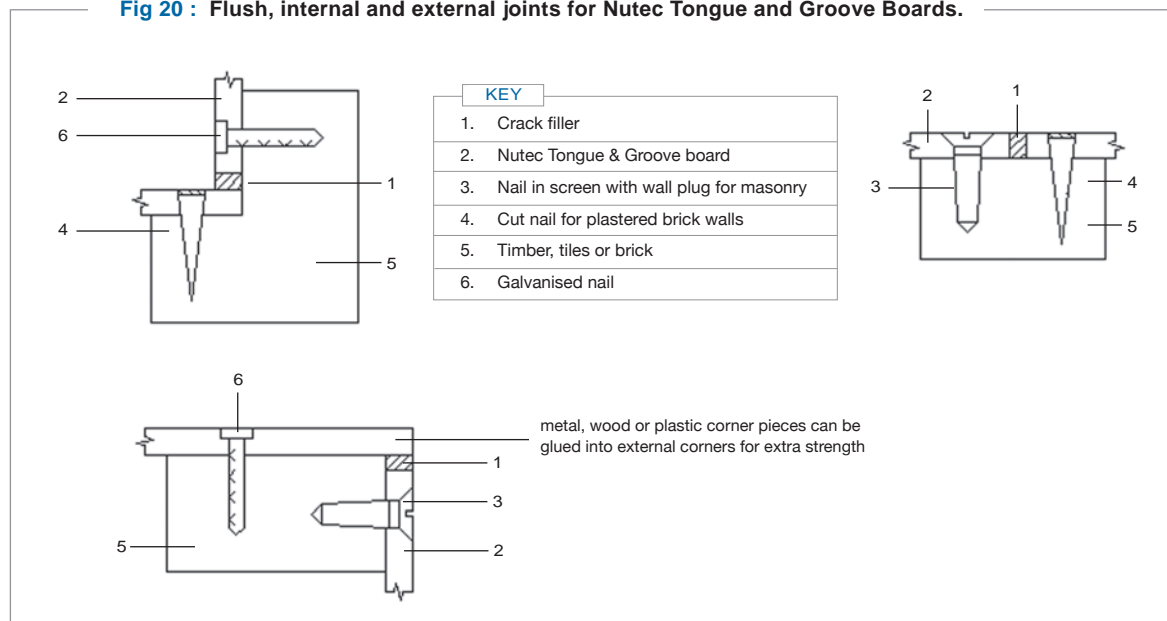

TONGUE AND GROOVE INSTALLATION

Fig 21 : Installing Nutec Tongue and Groove Board to even surfaces

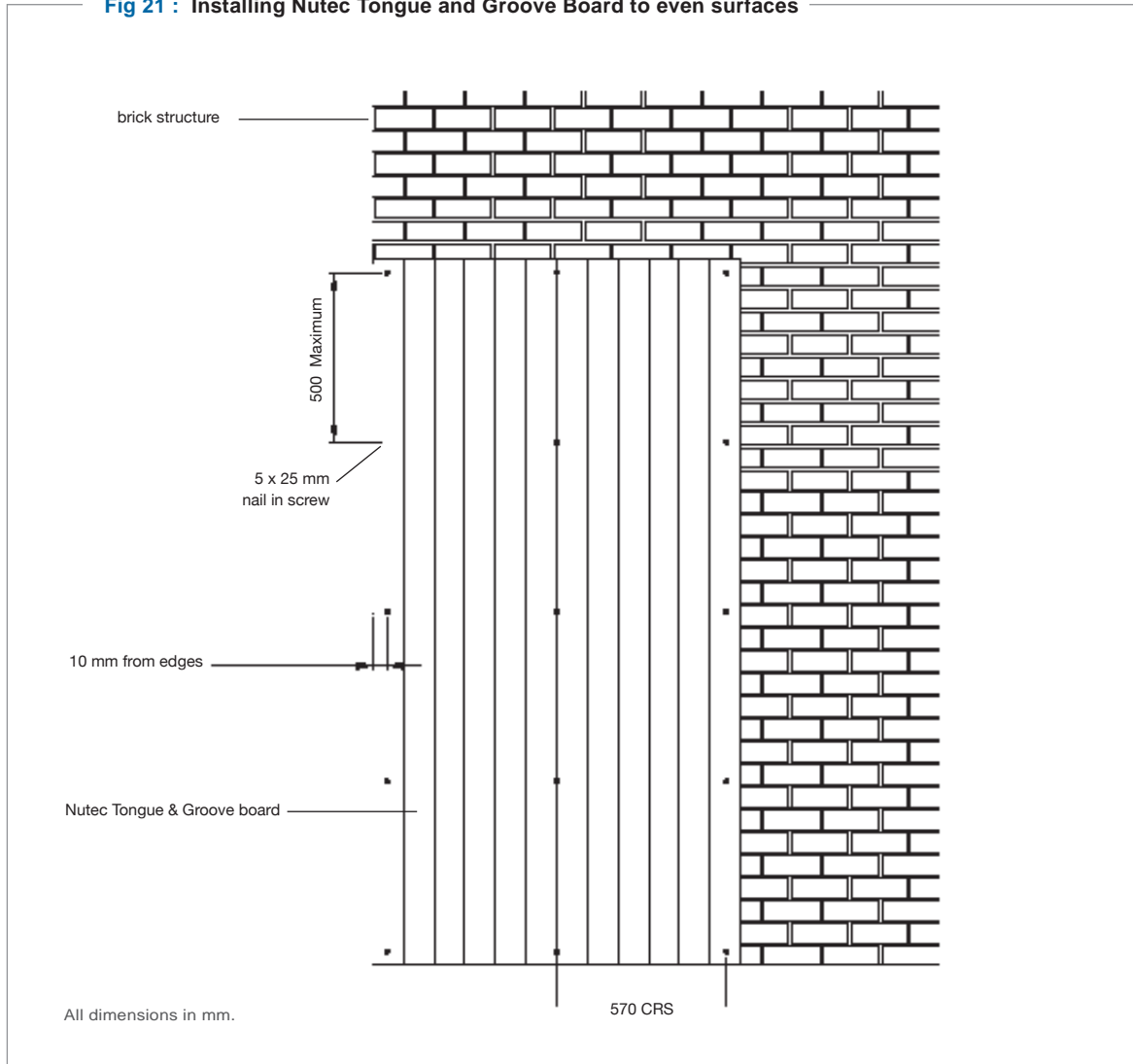

TONGUE AND GROOVE INSTALLATION

Fig 22 : Installing Nutec Tongue and Groove Board to uneven surfaces

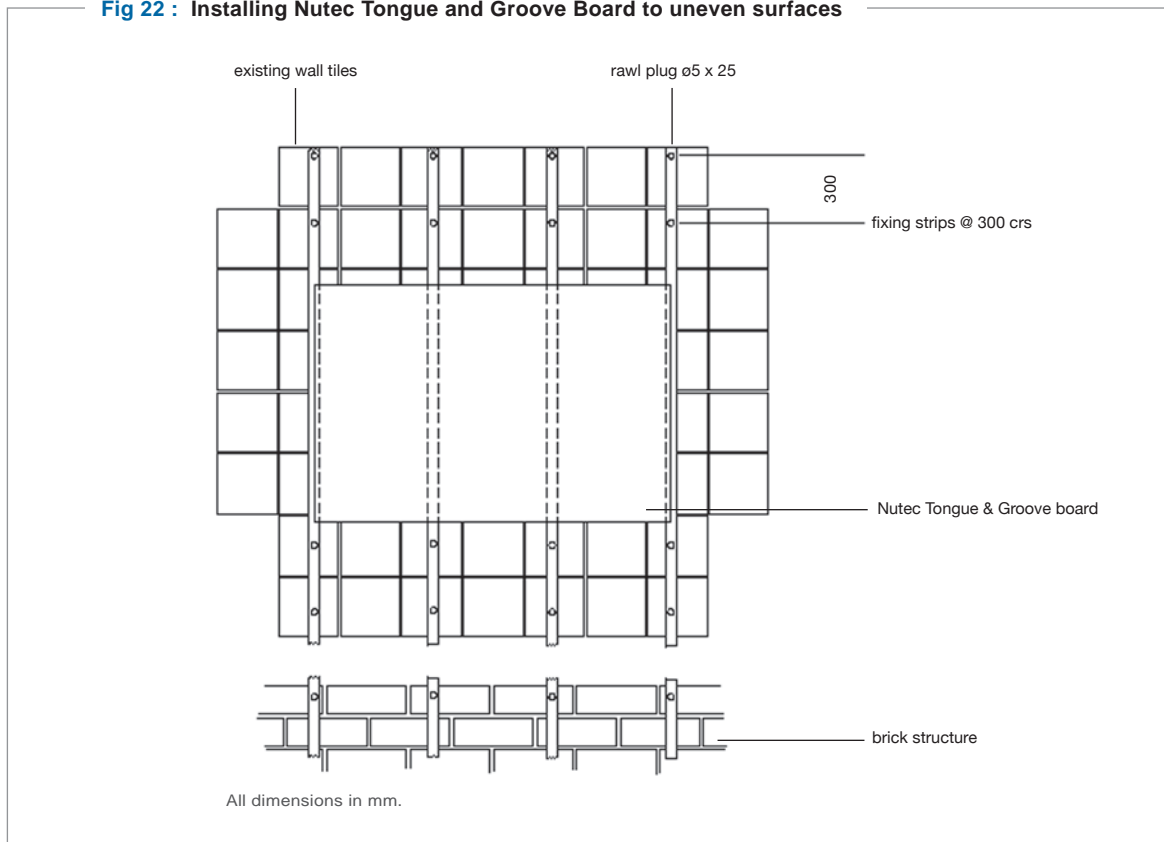

Things to remember when installing Nutec Tongue and Groove Boards.

- Nutec Tongue and Groove Boards may be applied to timber frames, plastered and unplastered walls and tiled surfaces as shown in [figure 21](#).
- Standard dado rails can be easily attached onto the wall above or below Tongue and Groove boards except when fixing strips are used. In such cases a shelf should be used instead.
- Fixing to uneven walls may required the use of fixing strips ([figure 22](#)) to ensure that the board remains flat and does not follow an uneven contour.
- Fixing strips must be fastened to the wall with nail in screws at 300 mm intervals. The irregularity of the wall will determine the thickness of timber used but a minimum of 15 mm should be adhered to.
- Spacer must be used at relevant fixing points behind the strips to compensate for the irregularities in the wall. A builders line must be used to draw a level across the strips.
- Nutec Tongue and Groove boards are attached to the fixing strips at the same intervals as they would normally be attached using.
- For ceiling applications these boards should be fixed at 600 m centers as shown in [figure 23](#).
- When used in wet areas, the board must be sealed continuously around the perimeter of the reverse side of the board 5mm from the edge.
- To form a double skin wall in a prefabricated steel or timber framed structure, the cavity between the two skins should be ventilated. In these structures, especially in humid conditions, foil is often

TONGUE AND GROOVE INSTALLATION

installed as a moisture barrier and as an insulator. Ventilating the cavity will permit the evaporation of any condensation which may collect on the insulating material. The sheets are best painted with a pure acrylic PVA paint. Where it is intended to use oil or alkyd paints it is essential to prime the sheet with an alkali-resistant sealer. In this instance both faces of the product should be sealed.

Fig 23 : Installing Nutec Tongue and Groove Boards as a Ceiling

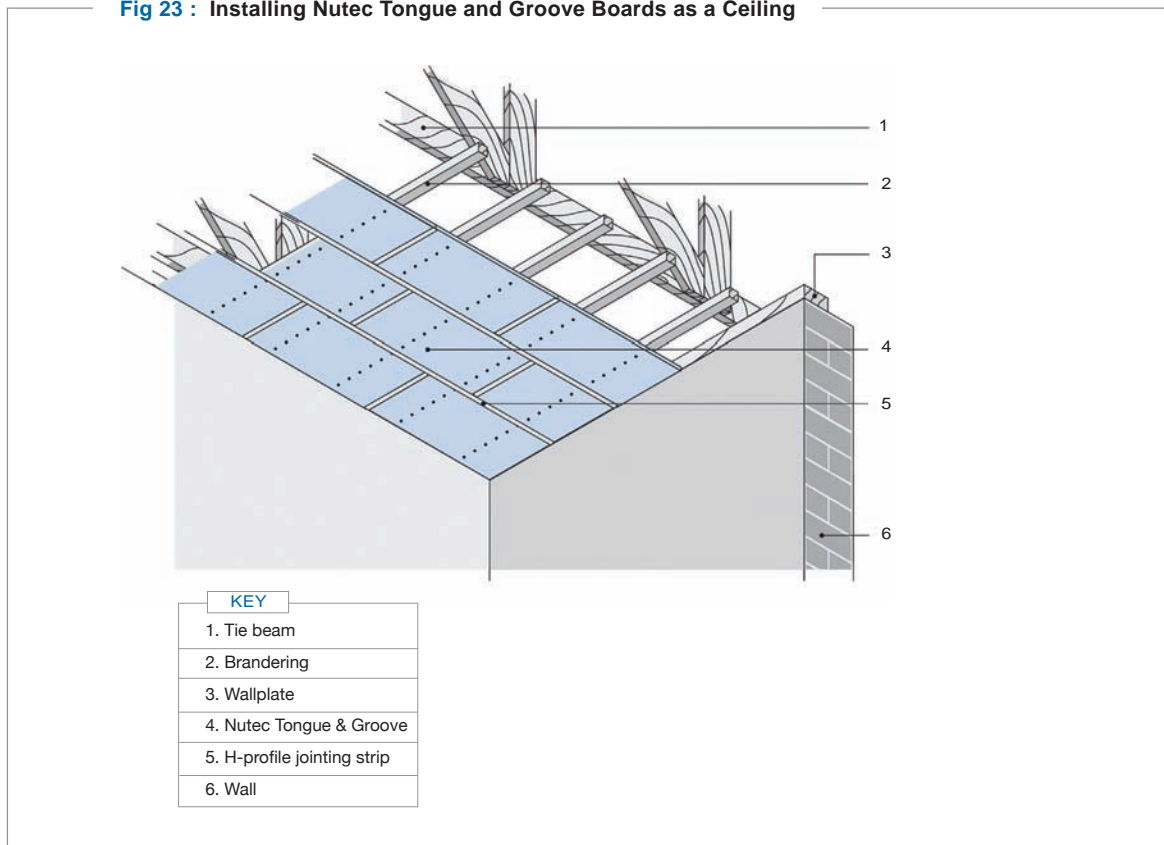

NB:

- Timber or steel framing may be used and should be constructed in accordance with local building regulations and acceptable building practice.
- Timber should be selected structural grade timber.
- Timber supports must be firmly secured to top and bottom plates and frames must not rely on the Nutec Flat Sheets for stability.
- Support spacings for external or internal walls should not exceed 600 mm centres.
- Framing members, should be arranged to support all sheet edges.
- Where the support faces behind sheet joints are less than 38 mm wide, pack out to provide additional landing for sheet fixing.
- For further information on timber framed structures refer to SABS 082 - the Code of Practice for Timber Buildings.

■ Floor / Ceiling Fire Resistant Systems

Fig 24 : General Plan of Arrangement of Floor/Ceiling 60 Minute Fire Rated System - Loading 1500 kN/m²

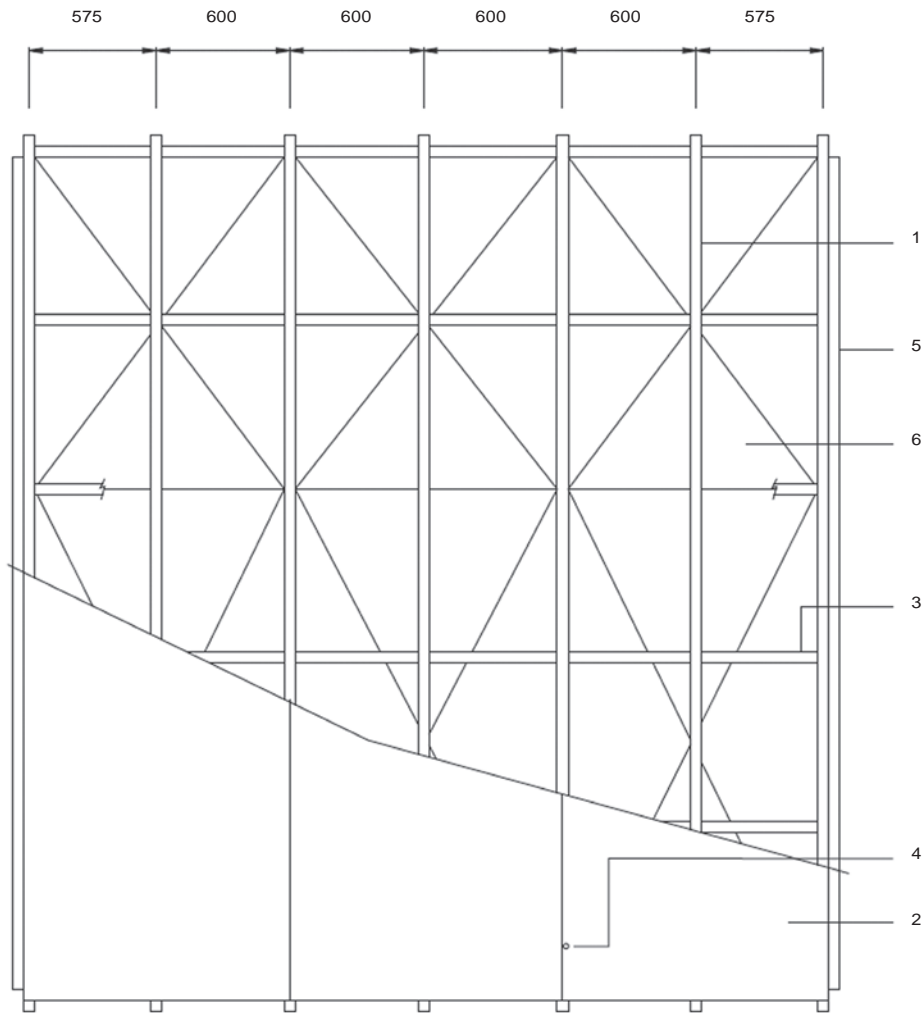

KEY

- | | |
|----|---|
| 1. | Softwood timber joists - 230 mm x 50 mm at 600 mm centre. |
| 2. | Floor Boards HD Nutec, 3600 mm x 1200 mm x 15 mm. |
| 3. | Softwood timber noggings at 600 mm centres by means of 100 mm nails. |
| 4. | 50 mm timber screws at 300 mm centres. |
| 5. | Mineral Fibre seal. |
| 6. | 6 mm Nutec Ceiling Board, 3600 mm x 1200 mm. Fixed with 50 mm timber screws at 300 mm centres to underside. |

Insulation: 50 mm Insulmate, 80 kg/m³.

Joints sealed with Intumex MA.

Screws and nail heads sealed with sodium silicate liquid.

Fig 25 : Typical 2-hour fire rated floor system

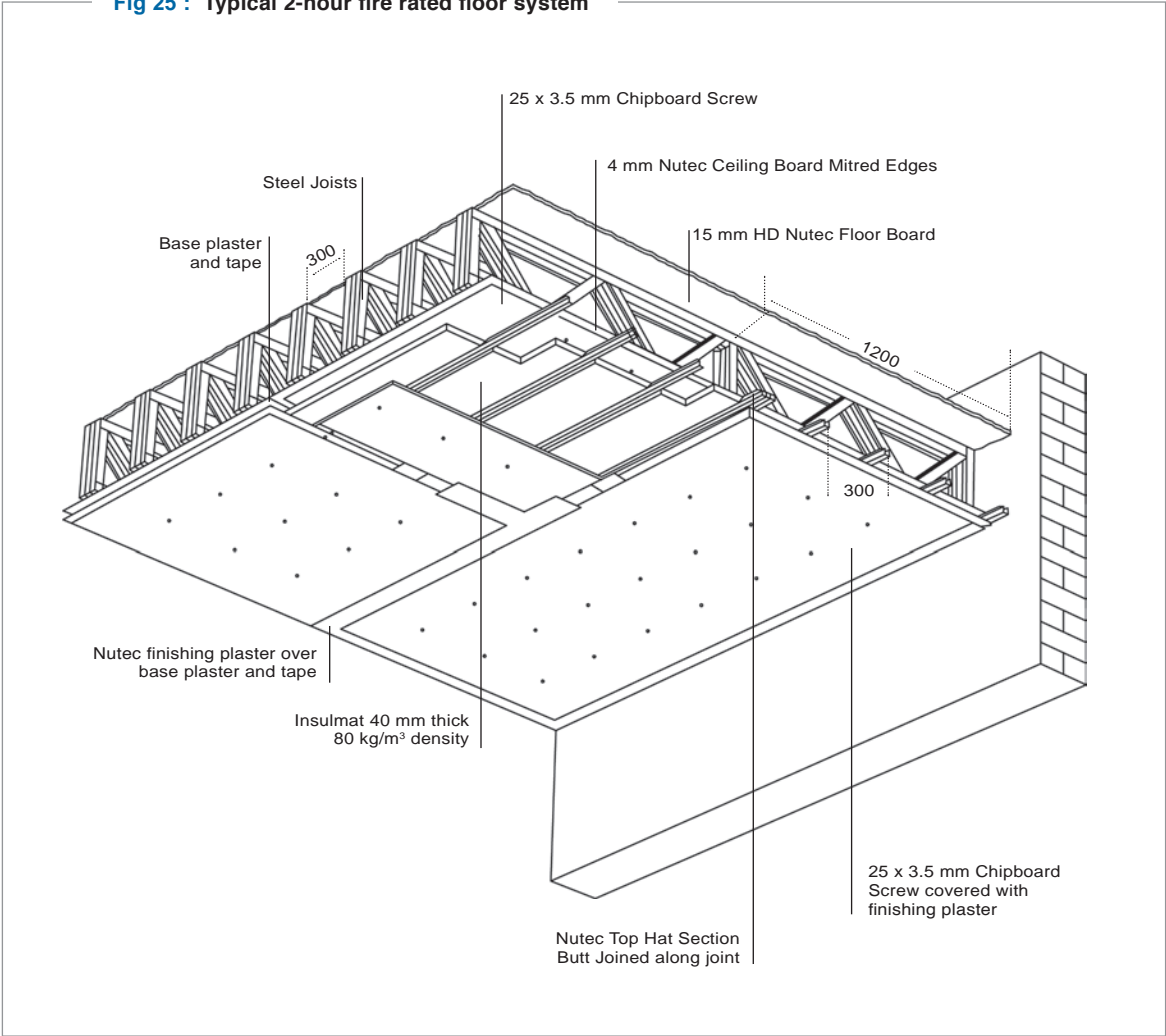

FIRE RESISTANCE SYSTEMS

Nutec Ceiling Boards in a suspended Floor System

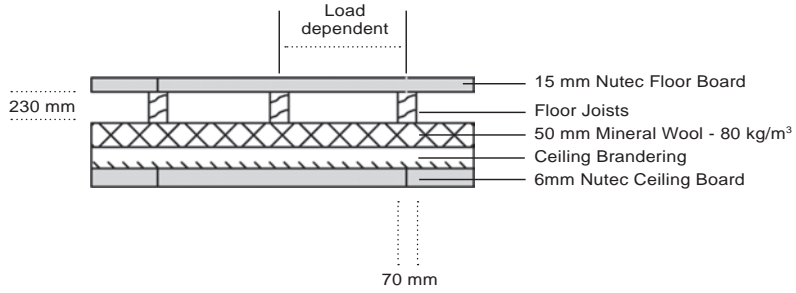
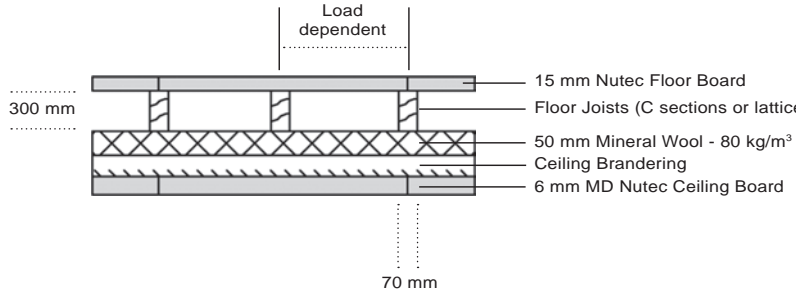
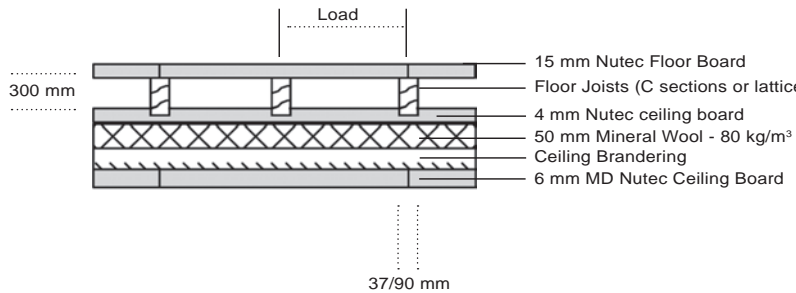
Fire Resistance	Timber Support Systems
60 minutes (structural)	 <p>Load dependent</p> <p>230 mm</p> <p>70 mm</p> <ul style="list-style-type: none"> 15 mm Nutec Floor Board Floor Joists 50 mm Mineral Wool - 80 kg/m³ Ceiling Brander 6mm Nutec Ceiling Board
Fire Resistance	Metal Support Systems
30 minutes (structural)	 <p>Load dependent</p> <p>300 mm</p> <p>70 mm</p> <ul style="list-style-type: none"> 15 mm Nutec Floor Board Floor Joists (C sections or lattice) 50 mm Mineral Wool - 80 kg/m³ Ceiling Brander 6 mm MD Nutec Ceiling Board
60 minutes (structural)	 <p>Load</p> <p>300 mm</p> <p>37/90 mm</p> <ul style="list-style-type: none"> 15 mm Nutec Floor Board Floor Joists (C sections or lattice) 4 mm Nutec ceiling board 50 mm Mineral Wool - 80 kg/m³ Ceiling Brander 6 mm MD Nutec Ceiling Board

Nutec Board for Fire Rated Walling Systems

Fire Resistance	Timber Frame Systems	Metal Frame Systems
30 minutes (non-structural)		
30 minutes (non-structural)		
60 minutes (non-structural)		
90 minutes (non-structural)		
90 minutes (non-structural)		

ACOUSTICAL AND THERMAL VALUES

■ Acoustical Insulation Walling Systems

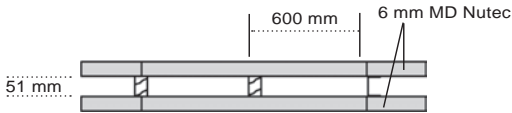
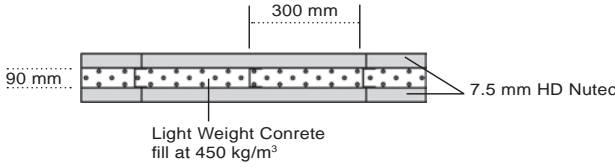
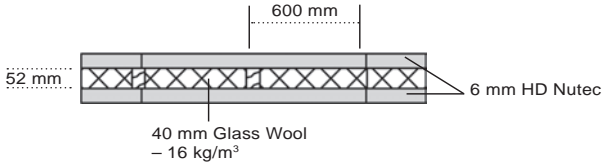
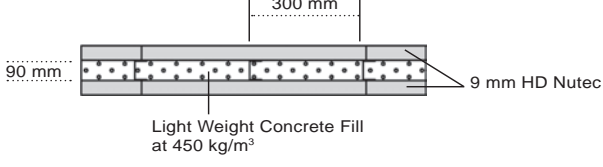
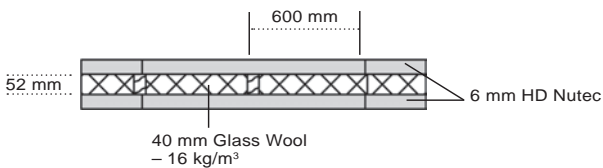
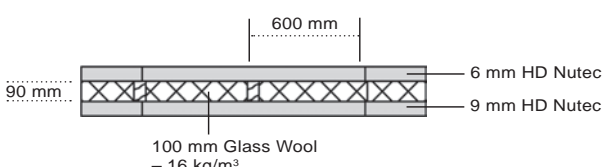
Acoustical Performance	System Details Timber or Steel	Thermal Resistance
26.0 dB	 4 mm Unpressed Fibre-Cement	0.02 m ² K/W
35.7 dB	 600 mm 6 mm MD Nutec 51 mm	0.06 m ² K/W
44.0 dB	 300 mm 90 mm 7.5 mm HD Nutec Light Weight Concrete fill at 450 kg/m ³	-
44.8 dB	 600 mm 52 mm 6 mm HD Nutec 40 mm Glass Wool - 16 kg/m ³	1.06 m ² K/W
45.0 dB	 300 mm 90 mm 9 mm HD Nutec Light Weight Concrete Fill at 450 kg/m ³	-
46.5 dB	 600 mm 52 mm 6 mm HD Nutec 40 mm Glass Wool - 16 kg/m ³	1.05 m ² K/W
48.0 dB	 600 mm 90 mm 6 mm HD Nutec 9 mm HD Nutec 100 mm Glass Wool - 16 kg/m ³	2.56 m ² K/W

ACOUSTICAL AND THERMAL VALUES

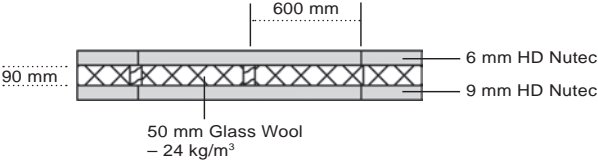
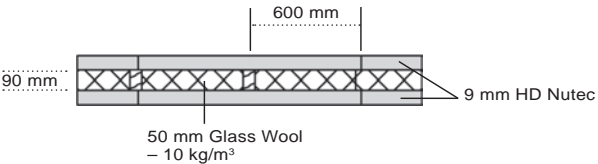
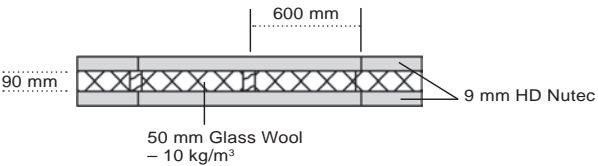
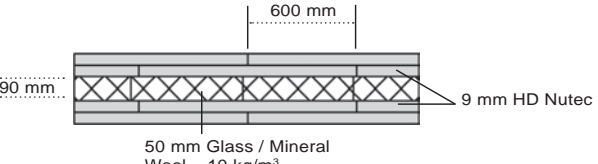
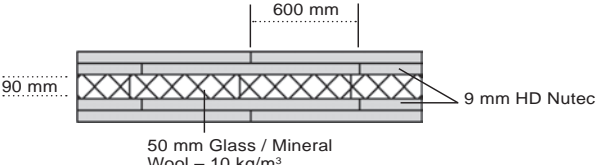
Acoustical Performance	System Details Timber or Steel	Thermal Resistance
48.0 dB	 <p style="text-align: center;">600 mm</p> <p style="text-align: center;">90 mm</p> <p style="text-align: center;">50 mm Glass Wool – 24 kg/m³</p> <p style="text-align: right;">6 mm HD Nutec 9 mm HD Nutec</p>	2.76 m ² K/W
48.0 dB	 <p style="text-align: center;">600 mm</p> <p style="text-align: center;">90 mm</p> <p style="text-align: center;">50 mm Glass Wool – 10 kg/m³</p> <p style="text-align: right;">9 mm HD Nutec</p>	1.44 m ² K/W
49.0 dB	 <p style="text-align: center;">600 mm</p> <p style="text-align: center;">90 mm</p> <p style="text-align: center;">50 mm Glass Wool – 10 kg/m³</p> <p style="text-align: right;">9 mm HD Nutec</p>	2.56 m ² K/W
55.0 dB	 <p style="text-align: center;">600 mm</p> <p style="text-align: center;">90 mm</p> <p style="text-align: center;">50 mm Glass / Mineral Wool – 10 kg/m³</p> <p style="text-align: right;">9 mm HD Nutec</p>	1.44 m ² K/W
56.0 dB	 <p style="text-align: center;">600 mm</p> <p style="text-align: center;">90 mm</p> <p style="text-align: center;">50 mm Glass / Mineral Wool – 10 kg/m³</p> <p style="text-align: right;">9 mm HD Nutec</p>	1.44m ² K/W

MECHANICAL AND PHYSICAL PROPERTIES

Mechanical and Physical Properties

■ Plain and Textured Nutec Flat Sheets

Parameter	Unit	High Density	Semi-High Density	Medium Density	Textured Nutec	Test Method
Specifications						
DIMENSIONS						
Thickness Tolerance:						
9 mm	mm	-	± 0.3	± 0.8	± 0.8	SANS 803
10 mm	mm	± 0.8	-	-	-	SANS 803
12 mm	mm	-	± 0.8	-	-	SANS 803
15 mm	mm	± 1.0	-	-	-	
Length Tolerance:						
All lengths	mm	± 2	+0 or -5	+3 or -5	+3 or -5	SANS 803
Width Tolerance:						
All widths	mm	± 2	+0 or -2	+3 or -5	+3 or -5	SANS 803
Squareness						
All sizes	mm	Maximum 5	Maximum 2	Maximum 5	Maximum 5	SANS 803
Edge Trueness						
All sizes	mm	Maximum 1	Maximum 3	Maximum 5	Maximum 5	SANS 803
Physical Properties						
Minimum MOR :						
With Grain	MPa	9.00 ⁽²⁾	8.44 ⁽¹⁾	7.40 ⁽¹⁾	7.40 ⁽¹⁾	SANS 803
Minimum MOR :						
Across Grain	MPa	13.00 ⁽²⁾	12.10 ⁽¹⁾	10.60 ⁽¹⁾	10.60 ⁽¹⁾	SANS 803
Target Density	g/cm ³	1.50	1.35	1.26	1.26	ISO 8336
Maximum Hygral Linear Expansion	mm/m	2.47	2.47	2.47	2.47	SANS 803

(1) Dried till constant weight (2) Saturated with water (3) Equilibrium conditions

MECHANICAL AND PHYSICAL PROPERTIES

Parameter	Unit	High Density	Semi-High Density	Medium Density	Textured Nutec	Test Method
Typical Values						
Thermal Conductivity	W/m.K	0.30	-	0.19	0.19	ASTM C518
Thermal Expansion Coefficient						
20-70°C	°C-1	Negligible	-	Negligible	Negligible	SANS Doc. 722/W 1009
10-70°C	°C-1	4.21 x 10-6	-	9.31 x 10-6	9.31 x 10-6	ASTM C518
Moisture Movement						
With Grain	%	0.30	0.053	0.06	0.06	ASTM C1185
Across Grain	%	0.06	0.049	0.06	0.06	ASTM C1185
Moisture Content	%	6.92	2.53	6.25	6.25	ASTM C1185
Water Absorption	%	22.05	28.10	37.72	37.72	ASTM C1185
Permeability	-	No droplets	No droplets	No droplets	No droplets	SANS 685 ASTM C1185 BS 4624
Water Vapour Transmission	ng /Pa.s.m ²	97.154	-	276.79	276.79	ASTM E96
pH		10 -12	10 -12	10 -12	10 -12	
Mechanical Properties						
MOR :						
With Grain	MPa	-	6.20 ⁽²⁾	4.20 ⁽²⁾	4.20 ⁽²⁾	ASTM C1185
	MPa	14.40 ⁽³⁾	11.20 ⁽³⁾	7.50 ⁽³⁾	7.50 ⁽³⁾	ASTM C1185
	MPa	-	9.40 ⁽³⁾	11.20 ⁽³⁾	11.20 ⁽³⁾	BS 4624
MOR :						
Across Grain	MPa	-	8.40 ⁽²⁾	7.75 ⁽²⁾	7.75 ⁽²⁾	ASTM C1185
	MPa	24.05 ⁽³⁾	18.50 ⁽³⁾	12.10 ⁽³⁾	12.10 ⁽³⁾	ASTM C1185
	MPa	-	15.60 ⁽³⁾	16.40 ⁽³⁾	16.40 ⁽³⁾	BS 4624

(1) Dried till constant weight (2) Saturated with water (3) Equilibrium conditions

MECHANICAL AND PHYSICAL PROPERTIES

Parameter	Unit	High Density	Semi-High Density	Medium Density	Textured Nutec	Test Method
Specifications						
Classification in Accordance to ASTM C1186	-	II	I	I	I	
Compressive Strength Parallel to Surface of Board						
With Grain	MPa	15.21	-	10.86 ⁽²⁾	-	ASTM C1186 ASTM D1037
	MPa	24.62	-	15.57 ⁽³⁾	-	ASTM D1037
Across Grain	MPa	20.61	-	11.54 ⁽²⁾	-	ASTM D1037
	MPa	37.22 ⁽³⁾	-	19.58 ⁽³⁾	-	ASTM D1037
Tensile Strength Parallel to Surface of Board						
With Grain	MPa	3.47 ⁽²⁾	-	2.11 ⁽²⁾	-	ASTM D1037
	MPa	5.12 ⁽³⁾	-	3.26 ⁽³⁾	-	ASTM D1037
Across Grain	MPa	4.34 ⁽²⁾	-	2.24 ⁽²⁾	-	ASTM D1037
	MPa	5.95 ⁽³⁾	-	2.88 ⁽³⁾	-	ASTM D1037
Tensile Strength Parallel to Surface of Board						
	MPa	1.42 ⁽²⁾	-	0.83 ⁽²⁾	-	ASTM D1037
	MPa	2.18 ⁽³⁾	-	1.02 ⁽³⁾	-	ASTM D1037
Young's Modulus (E.Mod)						
With Grain	MPa	9898 ⁽³⁾	-	5337 ⁽³⁾	-	ASTM C120
	MPa	7747 ⁽²⁾	-	3974 ⁽²⁾	-	ASTM C120
Across Grain	MPa	11645 ⁽³⁾	-	6474 ⁽³⁾	-	ASTM C120
	MPa	7903 ⁽²⁾	-	4681 ⁽²⁾	-	ASTM C120
Block Shear Strength						
	MPa	3.30 ⁽³⁾	-	1.60 ⁽²⁾	-	ASTM D143
	MPa	3.17 ⁽²⁾	-	1.32 ⁽³⁾	-	ASTM D143

(1) Dried till constant weight (2) Saturated with water (3) Equilibrium conditions

MECHANICAL AND PHYSICAL PROPERTIES

Parameter	Unit	High Density	Semi-High Density	Medium Density	Textured Nutec	Test Method
Fire Properties						
Surface Spread of Flame	Class	1	1	1	1	SANS 10177: Part 111, BS 476: Part 7
Spread of Flame Index	-	Nil	Nil	Nil	Nil	SANS 10177 Part III
Heat Contribution Index	-	Nil	Nil	Nil	Nil	SANS 10177 Part III
Smoke Emission Index	-	Nil	Nil	Nil	Nil	SANS 10177 Part III
Surface Fire Index	-	Nil	Nil	Nil	Nil	SANS 10177 Part III
Surface Burning Characteristics						
FSI (Flame spread index)	-	0	-	0	0	ASTM E84
SD (Smoke developed index)	-	5	-	3	3	ASTM E 84
Non-Combustibility		Non-combus.	Non-combus.	Non-combus.	Non-combus.	BS 476 Part 4, SANS 10177: Part V
Continuous Temperature	-	150°C	150°C	150°C	150°C	-

(1) Dried till constant weight (2) Saturated with water (3) Equilibrium conditions

MECHANICAL AND PHYSICAL PROPERTIES

Parameter	Unit	High Density	Semi-High Density	Medium Density	Textured Nutec	Test Method
Other Properties						
Frost Resistance Cycles Completed	-	50	-	50	-	ASTM C1185
Strength Ratio	%	97.5	-	78.5	-	ASTM C1185
Biological Resistance Rodent Resistance	Class	B1	-	B1	-	SANS 5417
Termite Resistance		No Damage	-	No Damage	-	SANS 5471
Resistance to Bacteria		-	-	No Growth	-	BS 5980

(1) Dried till constant weight (2) Saturated with water (3) Equilibrium conditions

CONTACT DETAILS

Everite National Offices

Call Centre 0861 333 835
+ 27 11 439 4400

www.everite.co.za



Sales Support Office

Telephone + 27 11 439 4400

Telefax + 27 11 903 7097

Bloemfontein

Mobile + 27 83 798 8049

Telefax + 27 51 522 1760

Cape Town

Telephone + 27 21 941 8640

Telefax + 27 21 941 8641

Durban

Telephone + 27 31 267 1903

Telefax + 27 31 267 1907

East London

Mobile + 27 79 516 6510

Telefax + 27 43 726 0343

George

Telephone + 27 44 873 2408

Mobile + 27 83 286 3435

Telefax + 27 44 873 2409

Middelburg (Mpumalanga)

Mobile + 27 83 778 2787

Polokwane

Telephone + 27 15 297 3559/62

Telefax + 27 15 297 3424

Port Elizabeth

Telephone + 27 41 401 8900

Mobile + 27 83 780 6162

Telefax + 27 41 486 1884

Worcester

Mobile + 27 83 286 3431

Telefax + 27 23 342 6966

Botswana (Gaborone)

Telephone + 27 11 439 4400

Telefax + 27 11 903 8327

Namibia

Mobile (00264) 81 124 2655

Telefax (00264) 64 40 5684

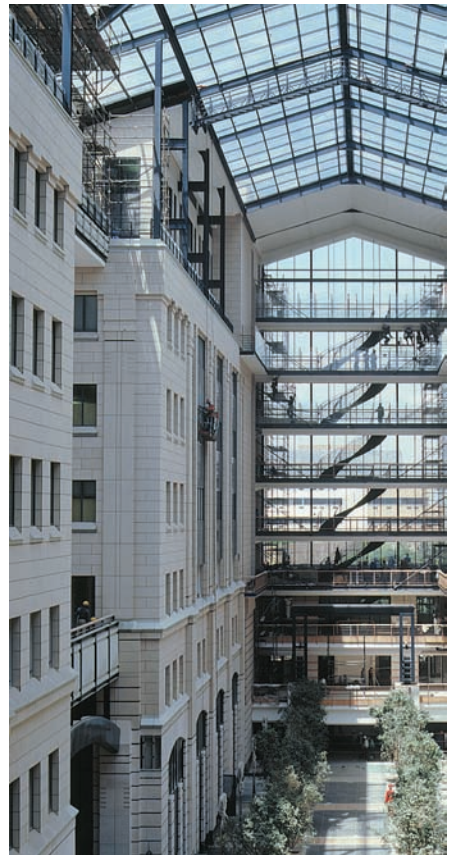

EVERITE

A subsidiary of
GROUP FIVE
structured ingenuity

www.everite.co.za
call centre: 0861 333 835

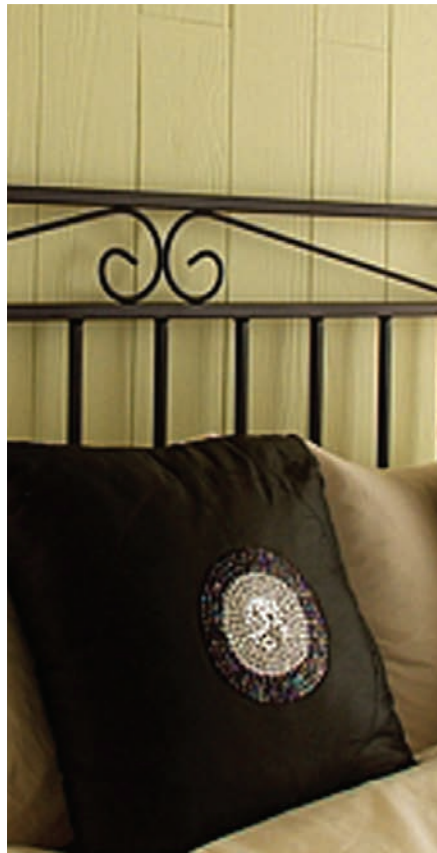

Copyright © 2012
Everite Building Products (Pty) Ltd.
All rights reserved.